



BIDDING DOCUMENT
FOR
CONSTRUCTION OF ROCK FALL
PROTECTION BARRIER FOR B-
BLOCK COLONY AT VPHEP.



THDC INDIA LTD.

VISHNUGAD – PIPALKOTI HYDRO ELECTRIC PROJECT

ALAKNANDAPURAM, SIYASAIN (JAISAL), PIPALKOTI,

DISTT.: CHAMOLI (U.K.) - 246472



LIST OF CONTENTS

Sl. No.	Section	Description
I	SECTION-I	Invitation to bid
II	SECTION-II	Information and Instructions to Bidders
III	SECTION-III	Prequalification Requirement
IV	SECTION-IV	General Conditions of Contract
V	SECTION-V	Special Conditions of Contract
VI	SECTION-VI	Contractor's labour regulation
VII	SECTION-VII	Annexure/ Proforma
VIII	SECTION-VIII	Technical Specifications & Drawings

**INDEX**

	Page No.
Section I - Invitation to bid	1-4
Section II Information and instruction to Bidders	1-9
Section III- Prequalification Requirement	1
Section IV - General Conditions of Contract	1-37
1.0 - Definition	1-3
2.0 – Document to be kept at Site	3
3.0 – Errors, Omission and Discrepancies	3-4
4.0 - Performance Security	4-5
5.0 - Refund of security deposit	5
6.0 - Commencement of work	5
7.0 - Deviations/ extent and pricing	5-6
8.0 - Rates for extra items/ altered items	6
9.0 - Variation in quantity	6
10.0 - Reduction in rates for substandard work	7
11.0 - Suspension of work	7
12.0 - Time and extension for delay	7-8
13.0 - Construction plant and machinery	8-9
14.0 - Materials	9-10
15.0 – Materials Supplied by the Corporation	10-18
16.0 - Taxes, duties and levies etc.	18-19
17.0 - Labour	19-20
18.0 - Permission for Contractor to enter on/take possession of the Site	20-21
19.0 - Setting out the works	21
20.0 - Site drainage	21
21.0 - Nuisance	21
22.0 - Materials obtained from excavation	21
23.0 - Treasure, Trove, Fossils etc.	21
24.0 - Protection of trees	21
25.0 - Watching and Lighting	22
26.0 - Contractor's Supervision	22
27.0 - Inspection and approval	22
28.0 - Duties and Powers of Engineer-in-Charge and EIC's representative	22-23
29.0 - Removal of Workmen	23
30.0 - Uncovering and making good	23
31.0 - Work during night or on Sunday and Holidays	23
32.0 - Completion Certificate	23-24



33.0 - Compensation for delay	24
34.0 - Defects liability period	24
35.0 - Contractor's liability and insurance	24-26
36.0 - Facilities to other Contractors	26
37.0 - Notices to local bodies	26
38.0 - Transfer of the contract and Sub-Contract	26-27
39.0 - Instructions and Notices	27
40.0 - Foreclosure of contract in full or in part	27
41.0 - Termination of contract	27
42.0 - Cancellation of Contract in full or in Part	27-29
43.0 - Liability for damage defects or imperfection & rectification thereof	29
44.0 - Urgent Works	29
45.0 - Changes in constitution	29-30
46.0 - Training of Apprentices	30
47.0 - Supply of Water for Construction purpose	30
48.0 - Arrangement of drinking water for labour	30
49.0 - Land for Contractor's office, store, Workshop etc.	30
50.0 - Power Supply	30-31
51.0 - Valuation and Payment	31-32
52.0 - Payment of final bills	32
53.0 – Contract Price Adjustment	32-34
54.0 – Overpayments and Underpayments	34-35
55.0 - Arbitration	35-36
56.0 - Force Majeure	36
57.0 –Discretion of Corporation	36-37
58.0 - Progress Report	37
59.0 - Time Schedule	37
60.0 - Law Governing the contract	37
61.0- Examination by CTE	37
Section-V – Special Conditions of Contract	1-6
Section VI-	1- 11
Contractor’s Labour Regulations & Rules	1-5
Model Rules of Labour Welfare	6-8
Safety requirements	9-11
Section VII – Annexure/ Proforma	1-25
Details of Bank Account (Annexure-A)	1
Form of Power of Attorney (Annexure-B)	2
Form for Declaration of Bidder (Annexure-C)	3



No Deviation Certificate (Annexure-D)	4
Tender Form (Annexure-E)	5-6
Warranty Form (Annexure-F)	6-7
Agreement Form (Annexure-G)	8-10
Bank Guarantee for EMD (Annexure-H)	10-12
Bank Guarantee for Performance Security (Annexure-I)	13-15
Indemnity Bond (Annexure-J)	16-17
RTGS/ NEFT Payment Details (Annexure-K)	18
Details Regarding Ex-Employees of THDC India Limited (Annexure-L)	19
No Claim Certificate (Annexure-M)	20
Material Accounting (Annexure-N)	21
Annexure – O	22
Annexure – P	23
Section VIII-	
Technical Specifications & Drawing	1-4



SECTION-I

INVITATION TO BID



टीएचडीसी इण्डिया लिमिटेड
(शिड्यूल – ए मिनीरत्ना पीएसयू)



THDC INDIA LIMITED
(Schedule - A Miniratna PSU)

NOTICE INVITING TENDER
(Domestic Competitive Bidding)

Tender No. THDCIL/VPHEP/PKOTI/22-23/04

THDC India Limited invites online open e-tender in two bid system through CPP portal website i.e. <http://eprocure.gov.in/eprocure/app> from eligible contractors for the following work:

Sl. No	Description of work	Estimated cost (₹)	EMD (₹)	Cost of tender documents including GST (₹)	Completion Period
01	Construction of Rock fall Protection Barrier for B-Block Colony at VPHEP	22,49,228/- (Excluding GST)	22,500/-	590/-	12 Months

Sale of Tender documents/submission start date: 11.08.2022 (09.30 Hrs)

Submission of Bids closing date: - on 12.09.2022 (upto 17.00 Hrs)

Opening of Techno-commercial Bid : - on 14.09.2022 (16:00 Hrs)

To participate in the tenders of THDC India Ltd. through e-tendering, the bidders are requested to log on CPP Portal web site <http://eprocure.gov.in/eprocure/app> after obtaining digital signature & registration in CPP Portal.

Pre-qualification requirements:

Pre-qualification requirements:

- 1) The bidder must have 'Average annual financial turnover' during the last 3 financial years, ending 31st March of the previous financial year, should be at least 30% of estimated cost.
- 2) Experience of having successfully completed similar works individually costing not less than as stated below during last 07 years ending last day of month previous to the one in which applications are invited should be either of the following:
 - (a) Three similar completed works costing not less than the amount equal to 40% of estimated cost.

OR
 - (b) Two similar completed works costing not less than the amount equal to 50% of estimated cost.

OR
 - (c) One similar completed work costing not less than the amount equal to 80% of estimated cost.

Definition of Similar work: - Rock Fall Protection arrangement in hilly areas.

The bidders have to furnish the experience certificate for satisfactory completion of work of similar nature as mentioned above. In the experience certificate, Agreement no., Completion value of work,



Name of work, Date of start, Date of completion and Signature of issuing authority with his name, designation, should be clearly mentioned. The experience certificate issued by PSU's/Central Govt./State Govt. or Semi Govt. Deptt. will be accepted. However Experience certificate issued by the private firm/company will be acceptable only, if supported by the TDS certificate.

(Note-Relaxation in Pre Qualification requirements is applicable as per tender terms & conditions).

If latest annual financial report (balance sheet and profit & Loss account) for assessing average annual financial turnover, is submitted as 'provisional' issued by the CA engaged by the Company, the successful bidder will finally submit their 'Final Balance Sheet'.

Note:

1. Bidders shall submit /upload the following documents with the Techno-commercial bid (Part-I):
 - a) Copy of Experience certificate as mentioned above in Pre-Qualification requirement
 - b) Copy of supporting documents in respect of average annual Turnover (Copy of certified /or audited by CA as the case may be) for the financial year 2019-20, 2020-21 & 2021-22 as mentioned above in Pre-Qualification requirement;
 - c) Copy of DD/BG/MSEs certificate (towards Exemption of Tender Cost & EMD) /UTR slip etc. towards tender cost & EMD;
 - d) Copy of PAN No.
 - e) Copy of GST registration no. as per applicable GST Act.;
 - f) Copy of EPF Registration and EPF code number under the "Employees provident fund and Miscellaneous provision Act. 1952";
 - g) Copy of MSEs or startup certificate if applicable.
 - h) Copy of duly filled Details of Bank Account (Annexure-A), Power of Attorney (Annexure -B, if applicable), Declaration of Bidder (Annexure-C), No Deviation Certificate (Annexure-D), Tender Form (Annexure-E) in bidder's letter head; Warranty Form (Annexure-F) on non-judicial stamp paper, RTGS/NEFT payment details (Annexure-K), Annexure - L and Annexure - O as per format annexed with tender documents;
 - i) Other required documents etc. as per tender conditions;
2. Any subsequent modification/ changes/corrigendum/ amendments/ notice to the above NIT shall be displayed / hosted in CPP Portal website <http://eprocure.gov.in/eprocure/app> only and the applicants are advised to be vigilant in this regard.
3. Blank space of documents such as Details of Bank Account (Annexure-A), Power of Attorney (Annexure -B, if applicable), Declaration of Bidder (Annexure-C), No Deviation Certificate (Annexure-D), Tender Form (Annexure-E) in bidder's letter head; Warranty Form (Annexure-F) on non-judicial stamp paper, RTGS/NEFT payment details (Annexure-K), Annexure - L and Annexure - O should be duly filled by the bidder otherwise liable to reject.
4. Bidders shall upload & submit all the requisite documents (as mentioned in the bidding documents) along with the Part-I (Techno-Commercial) of their bid in support of their Pre-qualification requirement on e-portal (CPP Portal) at the time of submission of their bid. The bids shall be evaluated only on the basis of documents /information uploaded & submitted by the bidders. The request of bidders(s) to submit documents/information after deadline of submission of bid(s) shall not be entertained. However, during evaluation of the bids, the 'Owner' may request the bidder(s) for any clarification pertaining to their bid(s), if required.

Conditions:

- 1) Tender is invited in two parts bid system i.e. 1st part bid Part - I (Techno commercial bid) and 2nd Part-II (Price Bid). Part-I contains pre-qualification information & documentary evidence in support thereof, EMD and Tender Cost. Techno-commercial bid along with required documents



- shall be uploaded by the bidder, which will be opened on the due date. Part –II shall contain price bid only.
- 2) Pre qualification information & Techno-commercial bid (Part-I) will be opened by Committee members on due date in presence of bidders who wish to attend the opening. Price bid shall be opened subsequently for those bidders who meet PQ requirements and whose Techno commercial bids (Part-I) are acceptable to THDCIL.
 - 3) The tender shall remain valid for acceptance for 120 days from the date set of opening or extended date of opening of the tender.
 - 4) The bidder, who wishes to participate in the tender, are required to register themselves in CPP Portal through <http://eprocure.gov.in/eprocure/app> web site and to submit the cost of tender documents and requisite EMD in the physical form also. **Physical form of Tender cost and EMD (DD/BG/UTR slip/MSEs Certificate) must reach before due date & time of submission of Techno – commercial bid at our VPHEP, Pipalkoti office.** The address of Pipalkoti office to submit the physically form of Tender cost & EMD by hand/post is as “**DGM (C&MM) THDCIL, VPHEP, Alaknandapuram Siyasain (Jaisal), Pipalkoti Chamoli (Uttarakhand) - 246472**”. Bid without tender cost & EMD will not be considered and liable to reject.
 - 5) **Earnest Money Deposit (EMD) & Tender cost**
 - (i) Earnest money (EMD) & Tender cost may be deposited in the form of pay order or Demand Draft in favour of **THDC India Ltd.** payable at **Pipalkoti (Chamoli)** or irrevocable Bank Guarantee in prescribed form from a Nationalized/Scheduled Bank and valid till 30 days after the expiry of the offer i.e. 120 days. In case of BG, non-judicial stamp paper should be in the name of Bank issuing the Guarantee.
 - (ii) EMD& Tender cost can also be deposited through e-payment (RTGS/NEFT) directly in THDCIL bank account. Bidder should upload the UTN No. / Transaction ID with Part-I bid. Details of Bank A/C of THDCIL are as under:

I)	Account Holder Name	: THDC INDIA LIMITED
II)	Bank Name & Branch	: SBI, Pipalkoti, Distt.- Chamoli
III)	Current A/C No.	: 32929585045
IV)	IFSC Code	: SBIN0004905
V)	MICR code	: 246002008
 - 6) Please fill up the details of EMD payment on the e-tendering site and also upload the scan copy of DD/BC/UTR Slip/BG etc. with other documents. The intimation regarding submission of payment against tender cost and EMD through RTGS/NEFT/MSEs must be given by the bidders in advance before last date of submission of bid on e mail i.e. cmm.vphep@thdc.co.in.
 - 7) Micro and Small Enterprises (MSEs) registered with District Industries Centers (DIC) or Khadi and Village Industries Commission or Khadi and Village Industries Board or Coir Boards or National Small Industries Corporation (NSIC) or Directorate of Handicrafts and Handloom or having Udyog Aadhaar Memorandum or any other body specified by Ministry of Micro, Small and Medium Enterprises shall be entitled to avail the facilities as per Public Procurement Policy for MSEs.
 - 8) To avail the facilities as per Public Procurement Policy for MSEs & startups under the category relevant to the tendered work, requisite documents are to be uploaded with the bid and same shall be submitted in the office before submission/closing date of the bid through e-mail/by post.



- 9) Public Procurement Preference to Make In India, Order 2017 (and as revised/amended time to time) is applicable. Benefit under Public Procurement Preference to make in India, Order 2017 (and as revised/amended time to time) shall be given to eligible bidders, subject to submission of documentary proof by the bidder, required under said PPPMI order.
- 10) All Micro & Small Enterprises and all startups (whether MSEs or otherwise), falling within the definition as per Gazette notification- G.S.R. Dated 23.05.2017 or as amended from time to time shall be relaxed from meeting the qualification criteria in respect of prior turnover and prior experience as below.
“The turnover requirement specified in the qualification criteria shall be relaxed by 25% for the above firms.
The qualification criteria in respect of prior experience (in terms of value of work specified in experience criteria) shall be relaxed by 25% for the above firms.
The above relaxation is subject to meeting of quality and technical specification for which necessary documents shall be submitted by such bidders”.
- 11) If a bidder/firm does not quote in colored cell of BOQ (PRICE SCHEDULE), the bid shall be treated as non-responsive and will not be considered for evaluation.
- 12) Any combination of Firm/applicant in form of Joint Venture (JV)/consortium is not permitted.
- 13) Conditional tenders shall liable to be rejected.
- 14) THDCIL shall disclose the reasons for rejecting a tender or non-issuing a tender document where enquiries are made by the bidder (s).
- 15) Notwithstanding anything stated above, THDC INDIA Ltd. reserves the right to reject any or all the tenders or split the order in the overall interest of THDC INDIA Ltd.

DGM (C&MM)
VISHNUGAD - PIPALKOTI HEP, THDC INDIA LTD.,
PIPALKOTI, DISTT. CHAMOLI (UK),
01372-256347, 01372-256350, cmm.vphep@thdc.co.in



SECTION - II

INFORMATION AND INSTRUCTIONS TO BIDDERS



Section–II

INFORMATION AND INSTRUCTIONS TO BIDDERS:-

Instructions for Online Bid Submission:

The bidders are required to submit soft copies of their bids electronically on the CPP Portal, using valid Digital Signature Certificates. The instructions given below are meant to assist the bidders in registering on the CPP Portal, prepare their bids in accordance with the requirements and submitting their bids online on the CPP Portal.

More information useful for submitting online bids on the CPP Portal may be obtained at: <https://eprocure.gov.in/eprocure/app> .

REGISTRATION

- 1) Bidders are required to enroll on the e-Procurement module of the Central Public Procurement Portal (URL: <https://eprocure.gov.in/eprocure/app>) by clicking on the link “**Online bidder Enrollment**” on the CPP Portal which is free of charge.
- 2) As part of the enrolment process, the bidders will be required to choose a unique username and assign a password for their accounts.
- 3) Bidders are advised to register their valid email address and mobile numbers as part of the registration process. These would be used for any communication from the CPP Portal.
- 4) Upon enrolment, the bidders will be required to register their valid Digital Signature Certificate (Class II or Class III Certificates with signing key usage) issued by any Certifying Authority recognized by CCA India (e.g. Sify / TCS / nCode / eMudhra etc.), with their profile.
- 5) Only one valid DSC should be registered by a bidder. Please note that the bidders are responsible to ensure that they do not lend their DSC’s to others which may lead to misuse.
- 6) Bidder then logs in to the site through the secured log-in by entering their user ID / password and the password of the DSC / e-Token.

SEARCHING FOR TENDER DOCUMENTS

- 1) There are various search options built in the CPP Portal, to facilitate bidders to search active tenders by several parameters. These parameters could include Tender ID, Organization Name, Location, Date, Value, etc. There is also an option of advanced search for tenders, wherein the bidders may combine a number of search parameters such as Organization Name, Form of Contract, Location, Date, Other keywords etc. to search for a tender published on the CPP Portal.
- 2) Once the bidders have selected the tenders they are interested in, they may download the required documents / tender schedules. These tenders can be moved to the respective ‘My Tenders’ folder. This would enable the CPP Portal to intimate the bidders through SMS / e-mail in case there is any corrigendum issued to the tender document.
- 3) The bidder should make a note of the unique Tender ID assigned to each tender, in case they want to obtain any clarification / help from the Helpdesk.

PREPARATION OF BIDS

- 1) Bidder should take into account any corrigendum published on the tender document before submitting their bids.
- 2) Please go through the tender advertisement and the tender document carefully to understand the documents required to be submitted as part of the bid. Please note the number of covers in



which the bid documents have to be submitted, the number of documents - including the names and content of each of the document that need to be submitted. Any deviations from these may lead to rejection of the bid.

- 3) Bidder, in advance, should get ready the bid documents to be submitted as indicated in the tender document / schedule and generally, they can be in PDF / XLS / RAR / DWF/JPG formats. Bid documents may be scanned with 100 dpi with black and white option which helps in reducing size of the scanned document.
- 4) To avoid the time and effort required in uploading the same set of standard documents which are required to be submitted as a part of every bid, a provision of uploading such standard documents (e.g. PAN card copy, annual reports, auditor certificates etc.) has been provided to the bidders. Bidders can use “My Space” or “Other Important Documents” area available to them to upload such documents. These documents may be directly submitted from the “My Space” area while submitting a bid, and need not be uploaded again and again. This will lead to a reduction in the time required for bid submission process.

SUBMISSION OF BIDS

- 1) Bidder should log into the site well in advance for bid submission so that they can upload the bid in time i.e. on or before the bid submission time. Bidder will be responsible for any delay due to other issues.
- 2) The bidder has to digitally sign and upload the required bid documents one by one as indicated in the tender document.
- 3) Bidder has to select the payment option as “offline” to pay the tender fee / EMD as applicable and enter details of the instrument.
- 4) Bidder should prepare the EMD as per the instructions specified in the tender document. The original should be posted/couriered/given in person to the concerned official, latest by the due date & time of bid opening or as specified in the tender documents. The details of the DD/any other accepted instrument, physically sent, should tally with the details available in the scanned copy and the data entered during bid submission time. Otherwise the uploaded bid will be rejected.
- 5) Bidders are requested to note that they should necessarily submit their financial bids in the format provided and no other format is acceptable. If the price bid has been given as a standard BoQ format with the tender document, then the same is to be downloaded and to be filled by all the bidders. Bidders are required to download the BoQ file, open it and complete the white coloured (unprotected) cells with their respective financial quotes and other details (such as name of the bidder). No other cells should be changed. Once the details have been completed, the bidder should save it and submit it online, without changing the filename. If the BoQ file is found to be modified by the bidder, the bid will be rejected.
- 6) The server time (which is displayed on the bidders’ dashboard) will be considered as the standard time for referencing the deadlines for submission of the bids by the bidders, opening of bids etc. The bidders should follow this time during bid submission.
- 7) All the documents being submitted by the bidders would be encrypted using PKI encryption techniques to ensure the secrecy of the data. The data entered cannot be viewed by unauthorized persons until the time of bid opening. The confidentiality of the bids is maintained using the secured Socket Layer 128 bit encryption technology. Data storage encryption of sensitive fields is done. Any bid document that is uploaded to the server is subjected to symmetric encryption using a system generated symmetric key. Further this key is subjected to asymmetric encryption using buyers/bid openers public keys. Overall, the uploaded tender documents become readable only after the tender opening by the authorized bid openers.



- 7) The uploaded tender documents become readable only after the tender opening by the authorized bid openers.
- 8) Upon the successful and timely submission of bids (ie after Clicking “Freeze Bid Submission” in the portal), the portal will give a successful bid submission message & a bid summary will be displayed with the bid no. and the date & time of submission of the bid with all other relevant details.
- 9) The bid summary has to be printed and kept as an acknowledgement of the submission of the bid. This acknowledgement may be used as an entry pass for any bid opening meetings.

ASSISTANCE TO BIDDERS

- 1) Any queries relating to the tender document and the terms and conditions contained therein should be addressed to the Tender Inviting Authority for a tender or the relevant contact person indicated in the tender.
- 2) Any queries relating to the process of online bid submission or queries relating to CPP Portal in general may be directed to the 24x7 CPP Portal Helpdesk. **The 24 x 7 Toll Free Telephonic Help Desk Number 1800-3070-2232. Mobile Nos 91-7878007972 and 91-7878007973**

1.0 GENERAL INSTRUCTIONS

- 1.1.0. Tenders are invited on behalf of the **THDC India Ltd.** having its head office at Rishikesh, for the work mentioned in NIT in Section-I.
- 1.2.0 The tender shall be submitted only in the prescribed Form and tender documents are not transferable.
- 1.3.0 The CMD of THDC INDIA Ltd or his authorized representative shall be the Accepting Officer hereinafter referred to as Accepting Authority for the purpose of this contract.
- 1.4.0 The bidder may submit the following with documentary evidence in support of his capacity and capability to execute the tendered works:
 - (a) Copy of satisfactory performance report (s) of the works executed and details of works in hand.
 - (b) Copy of balance sheets and Profit & Loss account for the last three financial years.
 - (c) Copy of plant and machinery available along with proposed deployment for the tendered works.
 - (d) Details of manpower available and proposed deployment for the tendered works.
 - (e) Details of cash flow proposed for the works and its source.
 - (f) Details of proposed programme for quality assurance for the tendered works.
 - (g) Proposed work programme in line with time schedule in the form of Bar Chart/ PERT Network indicating major key events.
- 1.5.0 Issue of tender documents does not automatically mean that the party is considered qualified. THDC INDIA Ltd reserves the right to assess the bidder's capability and capacity to perform the Contract should the circumstances warrant such assessment in the overall interest of the Corporation.
- 1.6.0 Bidders are advised to visit, inspect and examine the site and its surroundings, local conditions and factors at their own cost and satisfy themselves before submitting their tenders as to the nature of the ground and sub-soil (so far as is practical) the form and nature of the site, the means of access/approach to the site, the accommodation they may require, working hours, layout of land, trees & shrubs that he/ they will have to cut, type of strata likely to be met and in general shall themselves obtain all necessary information as to risks, contingencies and other circumstances which may influence or affect their tender. Bidders are advised to note the geological, meteorological and topographical details from the office of THDCIL before submitting the tender. However, meteorological characteristics and climate data for site are available and can be seen in the office of the THDCIL for reference. The bidder shall be deemed to have full knowledge of the site, whether he inspects it or not and no extra charges, damages,



- claims consequent on any misunderstanding or otherwise on any account shall be considered by the THDCIL.
- 1.7.0 Submission of a tender by a bidder implies that he has read the tender notice and all other tender documents and has made himself fully aware of the scope and specification of the work to be done and considered all aspects including stores, tools and plant etc. to be issued to him, if any, by the Corporation and local conditions and other factors having bearing on the execution of the works.
- 1.8.0 The bidder shall closely peruse all the clauses, specifications and requirements etc., indicated in the tender documents, before quoting. Should the bidder have any doubt about the meaning of any portion of the tender specifications or find discrepancies or omissions in the specifications or if the tender documents are found to be incomplete or require clarifications on any of the technical aspects, scope of work etc., he may notify the owner in writing or by fax / e-mail before 15 days in advance of bid submission date at the owner's mailing address.
- 1.9.0 At any time prior to the deadline for submission of bids, the Owner may, for any reason, whether at his own initiative or in response to a clarification requested by any prospective bidder, modify the bid documents by issuing Amendment(s). The amendments will be issued to all applicants who have already purchased the tender documents from Owner and also will be hosted in the website of THDCIL/ CPP Portal.
- 1.10.0 The bidder shall closely peruse all the qualifying requirements as mentioned in Section-III and provide all information/certificates as required in the tender document with his bid, failing which bid may carry the risk of rejection. After bid submission no unsolicited correspondence will be considered for evaluation. However, to assist in the evaluation of bids, the Owner may, at his discretion, ask a bidder for a clarification of its bid, to be submitted within a stated reasonable period of time.
- 1.11.0 In order to offer prospective bidders reasonable time to take the Amendment into account in preparing their bid, the Owner, at his discretion, if required, may extend the deadline for the submission of bids.
- 1.12.0 Language of bid and all correspondence and documents relating to the bid exchanged between the bidder and the Owner shall be written in the English language provided that any printed literature furnished by the bidder may be written in any other language so long as accompanied by an English translation (duly certified by a Public Notary) of its relevant passages in which case, for purposes of interpretation of the bid, the English translation shall govern.
- 1.13.0 The tender is routinely invited under e-tendering process. The bidder may submit PQ & Techno-Commercial Bid (Part-I) through electronic mode (soft copy) and Price Bid (Part-II) through electronic mode only. The bidders are requested to download the entire bidding documents from the website <http://eprocure.gov.in/eprocure/app> from prescribed date and time in the NIT after online vendor registration in the above website by paying an online payment of required amount as given in the NIT through Debit/ Credit Card or through Net Banking. For registration, the prospective bidders are required to provide PAN, TIN etc as mentioned in the e-registration procedure. After the required registration for e-tendering is completed the prospective bidder can download the bid documents and the cost of bid documents as given in the NIT may be made through RTGS/ NEFT Fund Transfer to THDCIL current account. The Bank account details are furnished at Clause No. 1.52.0. The RTGS / NEFT transfer details may be provided in **Annexure-K**. Alternatively, the cost of bid document may be paid in favour of THDC India Limited by way of demand draft payable at location as per NIT. The cost of bid document viz. original DD/ copy of receipt of RTGS / NEFT transfer details can be submitted along with Part-I of the bid document. Otherwise, after the required registration, the prospective bidder can get the bid documents from the address mentioned in clause No. 1.20.0 on payment of the cost of tender documents in the form of DD. However, the bidder has to download price bid i.e. Part-II of bid documents from the website <http://eprocure.gov.in/eprocure/app> before prescribed date and time in the NIT only, for enabling him to participate in e- tendering process after registration and furnishing tender fee DD details. The procedure in regard to the registration for e-tendering, downloading of the tender document and up loading & submission of the bids on the tender wizard is given on the web site <http://eprocure.gov.in/eprocure/app>.
- 1.14.0 If exempted by the Govt., the Public sector undertaking/ Govt. Departments/ MSMEs need not furnish the tender documents cost on production of evidence in this regard.



- 1.15.0 i) A bidder should quote the tender rate (s) in figures only in the downloaded price schedule and submit the quoted price schedule electronically on the website only.
- ii) In case tenders are invited in traditional mode (other than e-tendering), a bidder should quote the tender rate (s) in figures as well as in words. The amount for each item should be worked out and the requisite totals given. Special care shall be taken to write rates in figures as well as in words, and the amounts in figures only in such a way that interpolation is not possible. The total amount shall be written both in figures and in words.
- 1.16.0 Rates for all the schedule items shall be quoted on the tender document/price schedule issued or provided by the owner failing which offer may carry the risk of rejection.
- 1.17.0 The bidders shall bear all costs associated with the preparation and submission of their bids and Owner will in no case be responsible or liable for those costs regardless of the conduct or outcome of the bidding process.
- 1.18.0 The bidders shall fill and complete in all respects various bid forms, data sheets and the price schedules attached with the bid documents. An authorized representative of the bidder shall initial all pages of the proposal.
- 1.19.0 Bidders shall not be eligible to claim any compensation / claim towards the cost incurred for participation in bidding process.
- 1.20.0 Bids shall be submitted at the following address:
THDC INDIA LIMITED
VPHEP, Alkandapuram Siayasain (Jaisal), Piaplkoti, Chamoli
Ph No 01372-256347
Email: cmm.vphep@thdc.co.in
- 1.21.0 The bidders should ensure the submission of their bids on or before due date and time of submission as prescribed in the NIT. Bids received after due date and time will not be considered and treated as rejected.
- 1.22.0 In case tenders are invited in traditional mode (other than e-tendering), the bidders are advised to submit their offer in 2 separate sealed envelopes, one containing "PQ details and Techno commercial" and other containing "Price Bid" duly super scribed. Both these envelopes can be kept in one sealed envelope. All the envelopes shall be marked with name of work, tender no and date and due date of opening.
- 1.23.0 The Bid duly filled in shall be signed by duly authorized representative with his usual signature and sealed by the bidder. The name (s) and designation(s) of all persons signing should also be typed or printed below the signature. The letter of authorization shall be evidenced by written power of attorney accompanying the bid (**as per Annexure-B**). All pages of the bid except for printed literature shall be initialed by the person(s) signing the bid.
- 1.24.0 Bids without tender fee & EMD (Earnest Money Deposit) will be summarily rejected.
- 1.25.0 The PQ and techno commercial bid (Part-I) shall only be opened at stipulated date and time in the presence of bidders who wish to be present. The Price bid (Part-II) shall be opened subsequently only of those bidders who meet the PQ requirements and whose techno-commercial bids (i.e. Part-I) are substantially responsive to the requirement of the tender document. Separate intimation regarding opening of price bids shall be given to the acceptable bidders accordingly.
- 1.26.0 **PRELIMINARY EXAMINATION**
Prior to the detailed evaluation of Bids, the owner will determine whether each Bid:
- (a) Complying with all the requirements of bidding document
 - (b) Provide with all the Technical Bid Forms duly filled in.
 - (c) Accompanied by the required earnest money deposit, cost of Bid documents and complete tender documents.
 - (d) Demonstrate that it has the necessary capability to execute the contract.
- 1.27.0 **EVALUATION OF BIDS:**
- 1.27.1 The Pre-Qualification information furnished by the bidder shall be evaluated with respect to the specified eligibility and PQ requirements. The bidder is required to fulfill the PQ Requirements.
- 1.27.2 The Owner will evaluate and compare only the bids which conform to the scope, Technical specifications and Commercial conditions as specified in the Bid documents and have been determined to be substantially responsive to the requirements of the bidding documents.



1.27.4 Variations, deviations, and other factors, which are in excess of the requirements of the Bidding Documents or otherwise result in the accrual of unsolicited benefits to Owner shall not be taken into account in bid evaluation.

1.28.0 RESPONSIVENESS OF BIDS:

1.28.1 For the purpose of this Clause, a substantially responsive Bidder is one which conforms to all the terms and conditions of the bidding Documents without material deviation or reservation. A material deviation or reservation is one which affects in any substantial way the scope, quality, or performance of the Work, or which limits in any substantial way, the Owner's rights or the Bidder's obligations under the Contract (inconsistent with the bidding documents), and in case the rectification of such deviation or reservation would affect unfairly the competitive position of other Bidders, presenting substantially responsive Bids.

1.28.2 If a Bid is not substantially responsive to the requirements of the bidding Documents, it may be rejected by the Owner, and may not subsequently be made responsive by the Bidder having corrected or withdrawn the non-conforming deviation or reservation.

1.29.0 NONCONFORMITIES, ERRORS, AND OMISSIONS:

1.29.1 Provided that a bid is substantially responsive the owner may waive any non-conformities or omissions in the bid that do not constitute a material deviation.

1.29.2 In evaluating the bids, the Owner will determine, for each bid, the Evaluated Bid Price by adjusting any correction for errors in the Bid Price.

1.29.3 Bids determined to be substantially responsive will be checked by the Owner for any arithmetic errors. In case errors are observed in price bid between quoted price in figures and in words or in amount worked out by the bidder, the following procedures will be followed to take care of such errors:

- a) If there is a discrepancy between the rates quoted in figures and in words, the rate in words shall be taken as correct.
- b) If the unit rate quoted in figures and words tallies but the amount is not worked out correctly, the unit rate quoted by the bidder shall be taken as correct.
- c) If the amount of the item is not worked out by the bidder or it does not correspond with the unit rate written either in figures or in words then the rate quoted in words shall be taken as correct.
- d) If there is an error in a total corresponding to the addition or subtraction of subtotals, the subtotals shall prevail.
- e) In the event no rate has been quoted for any item(s), leaving space both in figure(s), word(s) and amount, it will be presumed that the bidder has included the cost of this/these item(s) in other items quoted and rates for such unquoted item(s) shall be considered as zero and the total bid price shall be worked out accordingly.

During the evaluation the total amount of the bid will be adjusted by the owner in accordance with the above procedure. If the bidder does not accept the corrected amount, the bid will be rejected and EMD will be forfeited.

1.30.0 COMPARISON OF BIDS:

1.30.1 The bids shall be compared on the basis of the total price including all applicable relevant taxes quoted by bidder in the price schedule.

1.30.2 The evaluated bid prices of all the bidders shall be compared among themselves to determine the lowest evaluated bid and, as a result of this comparison, the lowest evaluated Bid will be selected for the award of the Contract.

1.31.0 Earnest Money Deposit:

1.31.1 The bid shall be accompanied by earnest money in a separate sealed envelope duly super scribed. The earnest money may be paid in any one of the following forms:

- (a) The Earnest Money Deposit (EMD) may be submitted through RTGS/ NEFT Fund Transfer to THDCIL account. The Bank account details are furnished at Clause No. **1.52.0**. The RTGS / NEFT transfer details may be provided in **Annexure-K**.
- (b) By pay order/demand draft in favour of THDC India Ltd. payable at Pipalkoti.
- (c) Irrevocable Bank Guarantee in prescribed form (**Annexure-H**) from a Nationalized/ Scheduled Bank.



- (d) Fixed Deposit Receipt issued by Nationalized/ Scheduled Banks endorsed in favour of **THDC India Ltd. A/c "Name of Party"**.
- (e) Post Office, National Defence Deposit Certificate, duly endorsed in favour of **THDC India Ltd. A/c "Name of Party"**.
- 1.32.2 In case of non-submission of the acceptable Earnest Money Deposit on or before the specified time of bid-submission, the bids will be rejected by the Owner as non-responsive.
- 1.32.3 If exempted by the Govt., the Public sector undertaking/ Govt. Departments/ MSMEs need not furnish the EMD on production of evidence in this regard.
- 1.32.4 On acceptance of the tender, the EMD of the successful bidder can be converted into part of initial Security Deposit. However, fresh bank guarantee for initial security shall be furnished by the bidder on Security Deposit Performa in case EMD has been given in the form of bank guarantee.
- 1.32.5 Successful bidder has to comply with the provision of Security Deposit clause of G.C.C. failing which the EMD of the successful bidder will be forfeited.
- 1.32.6 Earnest Money Deposit of all Unsuccessful Bidders will be discharged/ returned as promptly as possible after acceptance of award of contract by the successful bidder or rejection of all the bids.
- 1.32.7 No interest shall be payable on EMD by the corporation.
- 1.32.8 The Earnest Money Deposit of Bidder may be forfeited if:
- a) A Bidder withdraws or modifies his bid during the period of bid validity or extended period of validity, or
 - b) In the case of a successful bidder, if the Bidder fails within the specified time limit to accept Letter of Award unconditionally and:
 - i) to sign the Contract in accordance with clause 1.47.0 or to commence the work within the stipulated time period prescribed in the Letter of Award.
 - or
 - ii) to furnish performance security in accordance with clause 4.0 of General Conditions of Contract/Special Conditions of Contract.
 - or
 - c) if engaged in fraudulent, corrupt, coercive or collusive practice.
- 1.33.0 A bidder shall submit the tender, which satisfies each and every condition laid down in information and instructions to Bidders and other tender documents. Conditional tenders shall run the risk of rejection (**Annexure-D**).
- 1.34.0 THDCIL do not bind themselves to accept the lowest or any other tender or to give any reasons for their decision.
- 1.35.0 THDCIL reserve the right of accepting or rejecting any or all the tenders or splitting the tender into two or more parties or retender without assigning any reason whatsoever or accepting the whole or any part of the tender and bidder shall be bound to perform the same at his quoted rates.
- 1.36.0 THDCIL reserves the right to allow the Price preference to the Public sector undertaking/ Govt. Departments/ MSMEs as per prevailing Govt. policies/Directives.
- 1.37.0 The notice inviting tender and "Information and Instructions to Bidders" shall also form part of the Contract documents.
- 1.38.0 Tender submitted by bidder shall remain valid for acceptance for a period as mentioned in the NIT from the date set for opening or extended date of opening of the tender. The bidder shall not be entitled during the said period of validity without the consent in writing of the owner, to revoke or cancel his tender or vary the tender given or any item there in. In case varying any terms in regard thereof without the consent of owner in writing, the corporation shall forfeit his earnest money without issue of any notice to the bidder.
- 1.39.0 The bidder has to furnish necessary warranty Form and Tender Form as per the enclosed format (**Annexure-E, Annexure-F**).
- 1.40.0 The bidder is to get himself registered with the respective local Authorities for the works to be carried out, if mandated under the local laws. Copy of such registration may be furnished with the tender.
- 1.41.0 Contractor shall not take or permit to be taken any photographs of the site or any part thereof publish or consent to the publication of any description thereof or any other matter relating



thereto without the previous written consent of Corporation. Contractor shall not erect any advertisement on notice board (except for such notice as shall be required for display by statute or by these General Conditions) on the site or on any other part of the site without first applying for and obtaining THDCIL's consent in writing. However, for progress reports, photographs shall be submitted by the bidder as asked from time to time.

1.42.0 The Contractor shall be deemed to have satisfied himself before tendering as to the correctness and sufficiency of his tender for the works and of the rates quoted in the schedule of Quantities and Prices which shall (except as otherwise provided in the Contract) cover all his obligations under the Contract and all matters and things necessary for the proper execution and completion of the works in accordance with the provisions of the Contract and its maintenance during construction.

1.43.0 No Bidder shall contact the Owner directly or indirectly or through his employees or agents on any matter relating to its bid from the time of bid opening to the time till Contract is awarded.

1.44.0 Any effort by a bidder to influence the Owner in its decision on bid evaluation, bid comparison or Contract award may result in the rejection of the bid.

1.45.0 The Owner will award the Contract to the successful bidder whose bid will be determined technically and commercially substantially responsive and will be determined as the lowest evaluated bid.

1.46.0 NOTIFICATION OF AWARD:

1.46.1 Prior to the expiry of the period of bid validity including extension(s), the letter of award (LOA) will be issued to the successful bidder. The Owner will notify the successful Bidder by fax/ e-mail to be confirmed in writing by courier / registered letter that his bid has been accepted.

1.46.2 The notification of award will constitute the formation of the contract until the contract agreement has been formally signed.

1.47.0 SIGNING OF CONTRACT:

After notification of successful bidder, the successful bidder shall enter into a Contract Agreement with the Corporation within fifteen (15) days from the date of issue of LOI/Letter of Award or within such extended time as may be indicated by the owner. The Agreement shall be signed (format enclosed at **Annexure-G**) at the office of the owner on a date & time to be mutually agreed. The Contractor shall provide for signing of the Contract, appropriate power of attorney and other requisite documents. The Agreement will be signed in two originals and Contractor will be provided with one signed copy. One copy will be retained by Corporation. The Contractor shall provide free of cost to the Corporation all the engineering data, drawings and descriptive material submitted with the bid, in at least six (6) copies to form a part of the Contract immediately after issue of letter of Award, along with agreed bar chart/PERT Network and quality assurance plan. Subsequent to signing of the Contract, the Contractor at his own cost shall provide to the Corporation with at least ten (10) true copies of Agreement duly bound within thirty (30) days after the signing of the Contract.

1.48.0 The Contractor has to check and deal with all the disturbance by local people, if any and to maintain progress of work so as to complete the entire works within agreed time schedule, However, THDCIL will render all necessary assistance to the contractor in the matter as may be required from the Corporation.

1.49.0 The Corporation will reject a proposal for award if it determines that the Bidder recommended for award or any of his representatives, has been directly or through an agent, engaged in corrupt, fraudulent, collusive, coercive or obstructive practices in competing for the Contract in question.

(a) For the purpose of this provision, the above terms are defined as follows:

(i) "Corrupt practice" is the offering, giving, receiving or soliciting, directly or indirectly, of anything of value to influence improperly the actions of another party;

(ii) "Fraudulent practice" is any act or omission, including a misrepresentation, that knowingly or recklessly misleads, or attempts to mislead, a party to obtain a financial or other benefit or to avoid an obligation;

(iii) "Collusive practice" is an arrangement between two or more parties designed to achieve an improper purpose, including to influence improperly the actions of another party;

(iv) "Coercive practice" is impairing or harming, or threatening to impair or harm, directly or indirectly, any party or the property of the party to influence improperly the actions of a party;



- (v) “Obstructive practice” is Deliberately destroying, falsifying, altering or concealing of evidence material to the investigation or making false statements to investigators in order to materially impede any investigation into allegations of a corrupt, fraudulent, coercive or collusive practice; and / or threatening, harassing or intimidating any party to prevent it from disclosing its knowledge of matters relevant to the investigation or from pursuing the investigation.
- 1.50.0 The Corporation will forfeit the bid security of the bidder and the Corporation may declare a firm ineligible, either indefinitely or for stated period of time, to be awarded a contract if at any time it determines that corrupt, fraudulent, coercive or collusive practices were engaged by the Contractor or any of its representatives, during the bidding process or the execution of the contract.
- 1.51.0 The “Agency/Bidder” shall not be under a declaration of ineligibility for corrupt and fraudulent practices or banned/debarred /suspended from transaction/business dealing by Ministry of Power (Govt. of India) or by THDC India Ltd. Or appearing in the list of such bidders available on Central Public Procurement Portal (CPP Portal).
A declaration to this effect shall be submitted by the bidder as per enclosed ‘Annexure-C’.
- 1.52.0. The Owner shall disclose the reasons for rejecting a tender or non-issuing a tender document where enquiries are made by bidder(s).
- 1.53.0 THE BANK ACCOUNT DETAILS OF THDCIL**
1. Name of the beneficiary: **THDC India Limited**
 2. Name of the Bank: **State Bank of India**
 3. Address of the Bank: **SBI, Pipalkoti, Chamoli**
 4. Account No. **32929585045**
 5. Type of account: **Current**
 6. IFSC code of the Bank: **SBIN0004905**
 7. Bank telephone no. (with STD code): 01372 266203
 8. Bank fax no. (with STD code): 01372 266203
 9. Bank e-mail:.....



SECTION III

PREQUALIFICATION REQUIREMENT



PRE-QUALIFICATION REQUIREMENTS:

-----**AS PER NIT**-----



SECTION – IV

GENERAL CONDITION OF CONTRACT



SECTION-IV

GENERAL CONDITIONS OF CONTRACT

1. Definition:

1.0.1- Employer/Owner/Corporation/THDCIL shall mean THDC INDIA LIMITED having its registered office at Bhagirath Bhawan, Bhagirathi Puram, Tehri- 249001 (U.K) and shall include their legal representatives, successors and permitted assigns.

1.0.2- The "Accepting Authority" shall mean CMD, THDC INDIA Ltd or his authorized executive.

1.0.3- CONTRACT DOCUMENT:

The term Contract Documents shall mean and include the following, which shall be deemed to form an integral part of the Contract:

- (a) Notice inviting Tender, information & instruction to bidders, General condition of Contract, special conditions of Contract, Technical specifications, Drawings, Bill of quantities, Time schedule, any amendments/ clarifications issued to the bidders and all other documents forming part of Contract documents.
- (b) Contractor's tender proposal including the letters of clarifications between the Contractor and the Owner prior to the Award of Contract, to the extent they have been accepted by the Owner.
- (c) All the materials, literature, data and information of any sort given by the Contractor alongwith his bid, subject to the approval of the Owner.
- (d) Letter of Award with any agreed variations/deviations to the tender documents, if any.
- (e) Any modification to Letter of Award issued in the form of AMENDMENTS, if any.

All these documents taken together shall be deemed to form Contract.

1.0.4- The "Contractor" shall mean the individual or firm or company whether incorporated or not, undertaking the works and shall include legal representatives of such individual or persons composing such firm or incorporated company or successors of such firm or company, as the case may be and permitted assign of such individual, firm or company.

1.0.5- The "Contract Sum" or Contract value shall mean:

- (a) In the case of Lump Sum Contracts the sum for which the tender is accepted:
- (b) In the case of Percentage Rate Contracts the estimated value of the works as mentioned in the tender adjusted by the Contractor's percentage:
- (c) In the case of Item Rate Contracts the cost of the works arrived at after extension of the quantities shown in Schedule of quantities by the item rates quoted by the bidders for the various items.

The Contract sum may vary due to variation in quantities and extra items as issued in the form of amendments.

1.0.6- A "Day" shall mean a day of 24 hours from mid-night of mid-night to irrespective of the number of hours worked in that day.

1.0.7- "Engineer-in-Charge" shall mean the Engineering officer appointed by the Corporation or his duly authorised representative who shall direct, supervise and be in charge of the works for purposes of this contract.

1.0.8- "Engineer-in-Charge representative" shall mean any executive appointed/nominated by Engineer-in-Charge from time to time to perform the duties for purpose of this contract.

1.0.9- "Excepted Risks" are risks due to riots (Other than among Contractor's employees) and civil commotion (in so far as both these are uninsurable), war, invasion, act of foreign enemies, hostilities, civil war, rebellion, revolution, insurrection, military or usurped power, any acts of Government, damage from aircraft, acts of God, such as earthquake lightening and unprecedented floods and other causes over which the contractor has no control and accepted as such by the Accepting Authority or causes solely due to use or occupation by the "Corporation" of the part of works in respect of which a certificate of completion has been issued.

1.0.10- "Market Rate" shall be the rate as decided by the corporation on the basis of cost of materials and labour at the Site where the work is to be executed, plus fifteen percent (15%) to cover all indirect or direct expenses including overheads and profit (No percentage shall be added for material issued by THDCIL, if any).



- 1.0.11- Schedule (s) referred to in these conditions shall mean the relevant schedule (s) annexed to the tender papers issued by the Corporation or the Standard Schedule of rates prescribed by the Corporation and the amendments there to issued from time to time.
- 1.0.12- The "Site" shall mean the lands and/or other places on, under, in or through which the work is to be executed under the Contract including any other lands or places which may be allotted by the Corporation or used for the purpose of the Contract.
- 1.0.13- "Temporary Works" shall mean all temporary works of every kind required in or about the execution, completion or maintenance of the works.
- 1.0.14- "Urgent Works" shall mean any urgent measures which, in the opinion of the Engineer-in-Charge, become necessary during the progress of the work to obviate any risk of accident failure or which become necessary for security & safety.
- 1.0.15- A "Week" shall mean seven days without regard to the number of hours worked in any day in that week.
- 1.0.16- The "Works" shall mean the works to be executed in accordance with the Contract or part (s) thereof as the case may be and shall include all extra or additional, altered substituted works or temporary and urgent works as required for performance of the Contract.
- 1.0.17- Permanent works shall mean the permanent works to be executed and maintained in accordance with the Contract.
- 1.0.18- ISS/ BIS- means Indian standard Specification/ means Bureau of Indian Standards.
- 1.0.19- Month- means from the beginning of a given date of a calendar month to the end of the preceding date of next calendar month.
- 1.0.20- Quarter- means a period of 3 months reckoning 1st date of January, April, July & October counted to the last date of March, June, September & December respectively.
- 1.0.21- Specification- means the specifications referred to in the Tender/Documents and any modification thereof or addition/deletion as per requirement of works at site incorporated as per direction of Engineer-in-Charge or his representative and will be binding on the Contractor to execute the work accordingly.
- 1.0.22- Drawing- means the drawings referred to in the specifications and any modification of such drawings approved in writing by the Engineer-in-Charge and such drawings, as may from time to time, be furnished or approved in written by the Engineer-in-Charge.
- 1.0.23- Tests- means such tests required to be carried out by the Contractor as detailed in the Contracts document before or during execution of works under the Contract.
- 1.0.24- "Tests on Completion" shall mean the tests to be made/ carried out by the Contractor before works are taken over by THDCIL as provided for in the Contract and such other tests as may be required for the completion of the work.
- 1.0.25- "Mobilisation" shall mean establishment of sufficiently adequate infrastructure by the Contractor at "site" comprising of construction equipments, aids, tools & tackles such as power, water, communication etc, establishing man power organisation comprising of Resident Engineers, Supervisory personnel and an adequate strength of skilled and unskilled workers, who with the so established infrastructure shall be in a position to commence execution of work at site (s) in accordance with the agreed time schedule of completion of work. "Mobilisation" shall be considered to have been achieved if the Contractor is able to establish infrastructure as indicated above to begin work at site (s) location as per time schedule where so warranted in accordance with agreed schedule of work implementation to the satisfaction of the Engineer-in-Charge.
- 1.0.26- "Sub-Contractor" shall mean any person or persons or agencies engaged/ appointed by the Contractor and their legal representative or successors for whom the Contractor accepts in writing the full responsibilities to ensure that any materials supplied and/or the work executed by the Sub-Contractor is subject to the same general terms & conditions, specifications and other obligations and liabilities as if the works were executed by the Contractor.
- 1.0.27- Words imparting persons shall include Firms, Companies, Corporation, associations or body of individuals whether incorporated or not. Words imparting masculine gender or singular number shall also include the feminine gender and plural number and vice-verse where the Contract so requires or permits.
- 1.0.28- "Notice of Awards of Contract/ letter of Award" shall mean the official notice issued by the owner notifying the contractor that his proposal has been accepted.



1.0.29- "Date of Contract" shall mean the date on which Letter of Award/Telex of Award/ LOI issued to the Contractor.

1.0.30 "Commencement Date" shall mean the date of start of work as per LOA.

2.0.0- DOCUMENT TO BE KEPT AT SITE:

2.1.0- The Contractor shall be furnished, free of charge, two certified true copies of the Contract Documents except standard specification and the schedule of rates and all further drawing, which may be issued during the progress of the works. He shall keep one copy of these Documents on the Site in good order, and the same shall at all reasonable time be available for inspection and use by the Engineer-in-Charge, his representative or by other Inspecting Officers.

2.1.1- CONTRACT MATTERS TO BE TREATED AS CONFIDENTIAL:

None of these Documents shall be used by the Contractor for any purpose other than that of this Contract.

(i) All documents, correspondence, decisions and orders concerning the Contracts shall be considered as confidential and/or restricted in nature and the Contractor shall not divulge or allow access to them by unauthorized person.

(ii) The Contractor shall take necessary steps to ensure that all persons employed on any work in connection with this contract have noticed that the Indian Official Secrets Act, 1923 (XIX of 1923) with applicable amendments, applies to them and shall continue so to apply even after the execution of such works under the Contract.

2.2.0- Works to be carried out as per given specifications. If item is not available with given specifications then works to be carried out as per PWD/ID/CPWD specifications respectively or as per decision of Engineer-in-Charge.

2.2.1- The works to be carried out under the Contract shall, except as otherwise provided in this conditions, include all labour, materials, tools, plants, equipments and transport which may be required in preparation of and for and in the full and entire execution and completion of the Works. The description given in the Schedule of Quantities shall, unless otherwise stated, be held to include wastage on materials, carriage and cartage, carrying in return of empties, hoisting, setting, fitting and fixing in position and all other labour necessary in and for the full entire execution and completion, in accordance with good practice and recognised principles.

3.0.0 ERRORS, OMISSIONS AND DISCREPANCIES:

3.1.0 The several documents forming the Contract are to be taken as mutually explanatory of one another, detailed drawing being given Preference to small-scale drawing and figures of dimensions in preference to scale and Special Conditions in preference to General conditions of Contract.

3.2.0 In case of discrepancy between Schedule of Quantities, the specifications and or the Drawing, the following order of preference shall be observed:-

(a) Description in Schedule of Quantities

(b) Particular Specification and Special Conditions, if any.

(c) Drawings.

(d) General Specifications.

3.3.0 If there are varying or conflicting provisions made in any document forming part of the Contract, the accepting authority shall be the deciding authority with regard to the intention of the document.

3.4.0 Any error in description of quantity or rate in Schedule of Quantities or any omission there from shall not vitiate the Contract or release the Contractor from the execution of the whole or any part of the works comprised therein according to drawing and specifications or from any of his obligations under the Contract.

3.5.0 If on check there are found to be difference between the rates given by the contractor in words and figures or in the amount worked out by him in the schedule of quantities and general summary, the same shall be adjusted in accordance with the following rules:-

(a) In the event of a discrepancy between description in words and figures quoted by a bidder, the description in words shall prevail.

(b) In the event of an error occurring in the amount column of Schedule of quantities as a result of wrong extension of the unit rate and quantity the unit rate shall be regarded, as firm and extension shall be amended on the basis of the rate.



- (c) All errors in totaling in the amount column and carrying forward totals shall be corrected.
- (d) The totals of various sections of Schedule of quantities amended shall be carried over to the General Summary and tendered sum amended accordingly. The tendered sum so altered shall, for purpose of tender, substituted for the sum originally tendered and considered for acceptance instead of the original sum quoted by the bidder. Any rounding off of quantities or in sections of schedule of Quantities or in General Summary, by the bidder, shall be ignored.
- (e) In case of lump sum contracts based on Bill of Quantities (quantities not shown as provision), should any error in quantities or any omissions of items be discovered, the cumulative effect of which varies the Contract sum by more than 5% or Rs. 20,000/-, whichever is less, then the errors shall be rectified and the rectification dealt with as for deviations variations clause thereof, and the value thereof shall be added or deducted from the Contract Sum, as the case may be; provided that there shall be no rectification of any errors, omissions, or wrong estimates in the prices inserted by the Contractor in the Bills of Quantities.

4.0 PERFORMANCE SECURITY:

4.1.1- The contractor for due performance of contract, as specified in letter of Award, shall furnish Performance Security of five percent (5%) of the contract sum in any one of the following form:

- (a) By pay order/demand draft in favour of THDC India Ltd.
- (b) Irrevocable Bank Guarantee in prescribed form (**Annexure-I**) from a Nationalized/ Scheduled Bank.
- (c) Fixed Deposit Receipt issued by Nationalized/ Scheduled Banks endorsed in favour of THDC India Ltd. A/c "Name of Party"
- (d) Post Office, National Defence Deposit Certificate, duly endorsed in favour of THDC India Ltd. A/c "Name of Party". The Performance Security will be retained/kept valid for a period of 30 days beyond the date of completion/extended date of completion of the contract and completion of the defect liability period, whichever is later.

4.2.0- The Earnest Money Deposit (EMD) furnished by the contractor alongwith the tender shall be adjusted towards security deposit. In case the contractor fails to furnish the security as aforesaid within the specified time the Corporation shall have the right to forfeit the earnest money deposit and to withdraw the letter of Award.

4.3.1 Security Deposit (Retention Money): In addition to the above mentioned Performance security the THDCIL is entitled to deduct the security deposit at the time of making any payment to the contractor for the work done under the contract in the following manner.

- (i) Deductions towards security deposit shall be made from all on account payments/ progressive payments @ 5% of each bill for completed works upto five percent (5%) of the contract sum. Half of the security Deposit so recovered will be refunded on successful completion of work and the balance half within thirty days of completion of the defect liability period.

4.3.2 If the security is furnished in the form of bank guarantee the contractor has to extend the bank guarantee to cover the period of extension, if any, till the defect liability period. Failure on his part to do so shall be construed as breach of this contract and without prejudice to any other remedy provided in these conditions, the Corporation shall have the right to withhold payment and deduct the entire security amount from any money becoming payable to the contractor.

4.3.3 All compensation or other sums or money payable by the contractor to corporation under the terms of this contract may be deducted from or recovered by the sale of sufficient part of his security deposit or any other sum which may be due or may become due to the contractor by the corporation on any account what so ever and in the event of his security deposit being reduced by reason of any such deduction or sale as aforesaid, the contractor shall within 10 days thereafter deposit the amount by which his security deposit have been so reduced.

4.3.4 In case a Fixed Deposit Receipt of any bank is furnished by the contractor to the corporation as part of the security deposit and bank goes into liquidation, or for any other reason is unable to make payment against the said fixed deposit receipt the loss caused thereby shall be borne by the contractor and the contractor shall forthwith or on demand furnish additional security to the Corporation to make good the deficit.

4.3.5 Bank Guarantee, Bank Drafts, Govt. Securities, fixed deposit receipt as aforesaid shall be valid for one month after the date of expiry of Defects liability period under the contract.



4.3.6 Govt. papers tendered as security shall be taken at their face value only.

4.3.7 Recovery of additional security deposit due to variation over award price:

If the value of work being executed exceeds the award price due to quantity variation/ introduction of new/ extra/ substituted items, additional security to the extent of 10% of the excess over the award price (excluding price adjustment payments as provided in the contract) shall be recovered from the contractor's bill. At the end of execution of work, 10% of the total value of work executed should be available towards security deposit.

5.0.0- REFUND OF SECURITY DEPOSIT:

5.1.0- If not appropriated by the corporation under the provisions of this contract, the security or such balance thereof as may be left over after making the deduction will be refunded to the contractor after the Engineer-in-Charge has satisfied himself that all the terms of the contract have been duly and faithfully carried out by the contractor and on submission of the following by contractor:-

- (a) No demand/ claim certificate for executed value of contract (as per the enclosed format at **Annexure-M**).
- (b) As built drawings receipt certificate.
- (c) Operation & Maintenance manual receipt certificate (Wherever applicable).
- (d) Test Certificate & Quality Manuals receipt Certificate.
- (e) Material reconciliation & No recovery Certificate.
- (f) Payment reconciliation & No recovery Certificate.
- (g) Labour Payment certificate.
- (h) Statutory requirement compliance certificate.
- (i) Completion certificate.
- (j) Indemnity Bonds & Insurance Policy release certificate.
- (k) Any other requirement as per contract.

5.2.0- No interest shall be payable to the contractor against the security deposit furnished/ recovered from the contractor by the Corporation.

6.0.0- COMMENCEMENT OF WORK:

The Successful bidder is to deploy adequate man power and plant and Machinery at site within 15 days of date of issue of Award of contract/LOI for execution of works under the contract so as to complete the same within the stipulated time schedule stated in the contract documents or as agreed to in the contract.

6.1.0 The contractor shall be entitled to receive, on demand the following:-

- (a) Construction drawings & revision there to - 2 Sets
- (b) Revision in specification, if any - 2 Sets
- (c) Explanation and instructions - One

Specification and drawing are the proprietary items of THDCIL and should not be sold or passed on to third party or May not be used for any other purpose.

6.2.0 The modification in drawing and specifications, if any, will be as per requirement of work from time to time and may be issued by Engineer-in-Charge in writing and is binding on the contractor and same shall be deemed to form an integral part of the contract and contractor is bound to carry out the work accordingly.

7.0.0 DEVIATIONS / EXTENT & PRICING:

7.1.0 The corporation shall have power (i) to make alteration in, omission from, additions to or substitutions for the original specifications, drawing, designs and instructions that may appear to be necessary or advisable during the progress of the work and (ii) to omit a part of the work in case of non availability of portion of the site or for any other reasons, and the Contractor shall be bound to carry out the works in accordance with any alterations given to him in writing and such alterations, omissions, additions or substitution shall form part of the Contract as if originally provided therein and any altered, additional or substituted work which the Contractor may be directed to do in the manner above specified as part of the works, shall be carried out by the Contractor on the same conditions in all respects including price on which he agreed to do the main work.

7.2.0 The time for completion of the work shall, in the event of any deviations resulting in additional cost over the Contract Sum being ordered, be extended as follows if requested by the Contractor:-



- (a) In the proportion of such additional cost of the altered, additional or substituted work bears to the original Contract sum plus.
- (b) 25% of the time calculated in (a) above or such further additional time as may be considered reasonably by Corporation.
- 7.3.0 Rate for such additional altered or substituted work/ items shall be determined by the corporation as follows:-
- (i) If the rate for additional altered or substituted item of work is specified in the Schedule of Quantities the Contractor shall carry out the additional, altered or substituted item at the same rate or market rate whichever is less. In case of composite tenders where two or more schedule of quantities may form part of the contract, the applicable rate shall be taken from the schedule of quantities of that particular part in which the deviation is involved failing that at the lowest applicable rate for the same item of work in the other Schedule of Quantities.
- (ii) If the rate for any altered, additional or substituted item of work is not specified in the schedule of quantities, the rate for that item shall be derived from the rate for the nearest similar item specified therein or on market rate whichever is less. In case of composite tenders where two or more schedule of quantities form part of the contract, the rate shall be derived from the nearest similar item in the Schedule of Quantities of the particular part of works in which the deviation is involved failing that from the lowest of the nearest similar items in other schedule of quantities.
- (iii) If the rate for any additional, altered or substituted item of work cannot be determined in the manner specified in sub-para (i) and (ii) above, but items are available in CPWD, DSR then such item of work shall be carried out at the rate mentioned in CPWD Schedule of rates plus or minus the overall percentage as derived from the awarded price for DSR items as per CPWD schedule of rates or market rates whichever is less.
- (iv) If the rate for any altered, additional or substituted item of work cannot be determined in the manner specified in sub-para (i) to (iii) above, the Contractor shall within 14 days of the date of receipt of the order to carry out the said work, inform the Engineer-in-Charge under advice to the accepting authority of the rate which he proposes to claim for such items of work, supported by analysis of the rate claimed, and the Corporation shall within three months thereafter, after giving consideration to the rate claimed by the contractor, determine the rate on the basis of market rate(s). In the event of the contractor failing to inform the Engineer-in-Charge within the stipulated period of time, the rate which he proposes to claim the rate for such item shall be determined by the corporation on the basis of market rate(s).

8.0.0- Rate for Extra, Altered or Substituted Items:

The rate of extra items, altered items or substituted items etc., shall be paid as worked out above in clause 7.0 or market (Rates) which is less.

9.0.0- VARIATION IN QUANTITY:

9.1.0 The quantities of individual item appearing in Bill of Quantities/LOA may vary depending upon the site conditions and requirement of works. The permissible variation in the quantities is as under:-

- (a) Items to be executed below ground + **100%**
- (b) Items to be executed above ground + **20%**
- (c) There is no ceiling for reduction in the quantity of any individual item.

9.2.0 Contractor has to execute the individual items on the awarded rates for the variation limit as stated above in clause 9.1.0

9.3.0 In case quantity for any individual item exceeds beyond the variation limit stated in clause 9.1.0 then the rate of that item will be reduced by 3% (Three percent) for the excess quantity.

9.4.0 The total variation permissible over the contract value as awarded (inclusive of quantity variation and extra items) shall not exceed **twenty percent (20%)**.

9.5.0 Under no circumstances, the contractor shall at any stage suspend the work on his own.

10.0.0 REDUCTION IN RATE FOR SUBSTANDARD WORK:

10.1.0-Corporation shall have the right to accept sub-standard or defective work at reduced rates and to cause an audit and technical examination of work, running and final bills of the contractor including all supporting vouchers abstract etc. to be made before or after the payments of the final bills and if as a result of such acceptance of sub-standard or defective work audit and technical examination any sum is found to have been over paid in respect of any work done by



the contractor under the contract or any work claimed to have been actually executed, the contractor shall be liable to refund of the over payment and it shall be lawful for Corporation to recover the same from him in the manner prescribed in clause above or any other manner legally permissible and if it is found that the contractor was paid less than what was due to him under it, the amount of such under payment may be duly paid by Corporation to the contractor, provided that the sub-standard or defective work accepted is not considered to be seriously defective by the Engineer- in- Charge and the rate of the work accepted is suitably reduced by him to compensate the Corporation and such reduction will be binding on the contractor and same shall not be referred to Arbitration.

11.0.0- SUSPENSION OF WORKS:

11.1.0-The Contractor shall, on receipt of the order in writing of the Engineer-in-Charge, suspend the progress of the work or any part thereof for such time and in such manner as the Engineer-in-Charge may consider necessary for any of the following reasons:

- (i) On account of any default on part of the Contractor; or
- (ii) for proper execution of the Works or part thereof for reasons other than the default of the Contractor; or
- (iii) for safety of the Works or part thereof.

The Contractor shall, during such suspension, properly protect and secure the Works to the extent necessary and carry out the instruction given by the Engineer-in-Charge.

11.2.0 If the suspension is ordered for reasons (ii) and (iii) in clause 11.1.0 above.

- i) The contractor shall be entitled to an extension of the time equal to the period of every such suspension plus 25%.
- ii) If the period of such suspension exceeds thirty days at a time the Contractor shall, in addition, be entitled to compensation, as the Accepting Authority may consider reasonable, in respect of salaries and/or wages paid by the Contractor to his employees and labour at site, remaining idle during the period of suspension plus 5% of such sum to cover indirect expenses of the Contractor provided the contractor submits his claim supported with documentary evidences to the Engineer-in-Charge within 14 days of the expiry of the period of 30 days.

11.3.0 If the works or part thereof is suspended on the order of the Engineer-in-Charge for more than three months at a time, except when suspension is ordered for reason, (i) in clause 11.1.0 above, the Contractor may after receipt of such order serve a written notice on the Engineer-in-Charge requiring permission within fifteen days from receipt by the Engineer-in-Charge of the said notice to proceed with the works or part thereof in regard to which progress has been suspended and if such permission is not granted within that time the Contractor, if he intends to treat the suspension, where it affects only a part of the works as an omission of such part or where, it affects the whole of the works, as an abandonment of the works by the Corporation shall within 10 days of expiry of such period of 15 days give notice in writing of his intention to Engineer-in-Charge. In the event of the Contractor treating the suspension as an abandonment of the contract by Corporation, he shall have no claim to payment of any compensation on account of any profit or advantage which he may have derived from the execution of the work in full but which he could not derive in consequence of the abandonment. He shall, however, be entitled to compensation, as the Accepting Authority may consider reasonable, in respect of salaries and or wages paid by him to his employees and labour at Site, remaining idle in consequence and of material collected which could not be utilized on the works, plus five percent to cover indirect expenses of the Contractor, provided the Contractor submits his claim supported with documentary evidences to the Engineer-in-Charge under advice to the Accepting Authority within 30 days of the expiry of the period of 3 months.

12.0.0- TIME AND EXTENSION FOR DELAY:

12.1.0- The time allowed for execution of works as specified in the contract document or the extended time in accordance with these Conditions shall be the essence of the Contract.

12.2.0- If the Contractor commits default in commencing the execution of the work, Corporation shall without prejudice to any other right or remedy be at liberty to forfeit the earnest money absolutely.

12.3.0- If the works be delayed by any of the following act for a continuous duration of 15 days

- (a) Force majeure, or
- (b) abnormally bad weather, or



- (c) serious loss or damage by fire, or
 - (d) civil commotion, local combination of workmen, strike or lockout, affecting any of the trades employed on the work, or
 - (e) delay on the part of other contractor or trade man engaged by Corporation in executing work not forming part of the contract, or
 - (f) non-availability of stores, which are responsibility of corporation to supply or
 - (g) increase in the quantum of work
 - (h) any other cause which, in the absolute discretion of the Accepting Authority and is beyond the Contractor's control; then upon the happening of any such event causing delay, the Contractor shall immediately give notice thereof in writing to the Engineer-in- Charge but shall nevertheless use constantly his best endeavors to prevent or make good the delay and shall do all that may be reasonably required to the satisfaction of the Corporation and shall do all that may be reasonably required to satisfaction of the Engineer-in-Charge to proceed with the works.
- 12.4.0- Request for extension of time, to be eligible for consideration, shall be made by the Contractor in writing within fourteen days of the happening of the event causing delay. The contractor may also, if practical, indicate in such a request the period for which extension is desired.
- 12.5.0- In any such case the Accepting Authority may give a fair and reasonable extension of time for completion of the work. Such extension shall be communicated to the Contractor by the corporation in writing.
- 12.6.0 In case of grant of extension of time under the present clause, except for suitable time extension, contractor shall not be entitled for any other claim or financial compensation for such extension of time.
- 13.0.0- CONSTRUCTION PLANT & MACHINERY:**
- 13.1.0 The contractor shall arrange at his own expenses all tools, plant and equipments (hereinafter referred to as T&P) required for execution of the work. Subject to availability, corporation may give tools, plants, equipments and machinery to the contractor on hire (**refer special conditions of contract**). Corporation's T&P hired to the contractor shall be conveyed by him at his expense from the place of issue to the site and back.
- 13.2.0 If the contractor requires any item of T&P on hire from the Corporation over and above the requirement indicated by him at the time of submitting his tender, the Corporation may give on hire if such item is available with the corporation at a reasonable rate fixed by the Corporation or as indicated in contract documents.
- 13.3.0 The period of hire will be reckoned from commencement of the date of issue up-to the end of the day of return (including all holidays) irrespective of the actual hour of issue and return. The contractor will be exempted from levy of any charge for the number of days he is called upon in writing by the Engineer-in-Charge to suspend execution of the work, provided Corporation's T&P in question has in fact remained idle with the Contractor because of the suspension, provided the Contractor, in case the period of suspension exceeds 11 days, returns Corporation's T&P to the place from where it was issued.
- 13.4.0 The hire charges shall be reckoned as under:
- 13.4.1 The first eight working hours (excluding a break of one hour) working day.
- 13.4.2 Every working hour or part thereof in excess of 8 working hours, at the rate of 1/8 of the hire charges for a working day, provided however, if the Corporation has paid more than at the rate of 1/8th of the wage of the crew for overtime under the minimum wages Act or any other law for the time being in force, the excess over 1/8th of the wages shall also be charged to the Contractor.
- 13.5.0 If any time the Corporation's T&P has not worked at all during a day except for a breakdown, or has been worked for four hours in a day, the Contractor will be charged for half a working day.
- 13.6.0 If any time the Corporation's T&P has stopped working on account of a breakdown before it has worked for four hours in a day, the Contractor will be charged for half a working day. If the item has stopped working after it has worked for more than four hours but less than eight hours, the Contractor will be charged for a full working day.
- 13.7.0 The hire charges cover financing cost, charges of crew, depreciation, stores for maintenance and cleaning purpose and fuel to start a machine at the time of issue. All other charges such as cost of



- fuel for running a machine, engine oil, kerosene oil etc. for working Corporation's T&P and all unskilled labour and water required for servicing wash out shall be borne by the contractor. The contractor shall permit the Engineer-in-Charge to carry out periodical maintenance of Corporation's T&P in accordance with these provisions, and there will be no deduction in hire charges for the period spent on such maintenance. However, the contractor shall be allowed to return the tools and plant (issued by the corporation) for purposes of repairs and for the duration of such repairs no hire charge shall be levied.
- 13.8.0 The contractor shall be responsible for care and custody of Corporation's T&P (including employment of chowkidars) during the period Corporation's T&P remain with him and any damage (fair wear and tear excepted) to any of the equipment except for Excepted Risks provided always the Contractor has taken precautions necessary to protect it from such risks) shall be made good at the Contractor's expenses to the satisfaction of the Engineer-in-Charge unless such damage is caused because of negligence of crew provided by the Corporation.
- 13.9.0 The Corporation gives no guarantee in respect of output of its T&P hired to the Contractor and no reduction in rates or any compensation shall be allowed on the ground that output or performance of Corporation's T&P was not to the Contractor's expectation.
- 13.10.0 Corporation's T&P hired by the contractor shall be returned by the contractor to the Engineer-in-Charge at the place of issue (unless otherwise directed) on completion of the work or section of the work or earlier on termination of the hire by the corporation as hereinafter provided on written notice by Engineer-in-Charge. The Corporation shall be entitled to terminate the hire on two days notice without assigning any reason whatsoever and the contractor shall have no claim to any payment of compensation or otherwise whatsoever on account of termination of hire of Corporation's T&P by the corporation.
- 13.11.0 A log book for recording hours during which every item of Corporation's T&P issued to the Contractor has worked each day shall be maintained by the member of the crew in charge thereof or any representative of the Engineer-in-Charge appointed on that behalf and shall be daily attested by the Contractor or his authorized representative. In case the Contractor contests correctness or any entry and/or fails to sign the log book, decision of the Engineer-in-Charge shall be final and binding on him. Hire charges shall be calculated in accordance with the entries in the logbook.
- 13.12.0 The charges payable by the Contractor shall be recovered from the Contractor's bills or any other payment due to him.
- 13.13.0 It is the sole responsibility of the Contractor to complete the work as per agreed time schedule whether he deploys his own T&P or hire some or all T&P from the Corporation.
- 14.0.0 MATERIALS:**
- 14.1.0 The contractor shall at his own expenses, provide all materials required for the works other than those which are to be supplied by the Corporation if so provided under **special conditions of contract**. All materials to be provided by the Contractor shall be new in conformity with the specifications laid down in the contract and the contractor shall, furnish proof to the satisfaction of Engineer-in-Charge that the materials so comply.
- 14.2.0 The Contractor at his own expenses and without delay shall supply to the Engineer-in-Charge/ QA Deptt. samples of materials as per specifications proposed to be used in the works free of cost. The Engineer-in-Charge / QA Deptt. shall within seven days of supply (or within such further period as he may require) intimate to the Contractor in writing, whether samples are approved by him or not. If samples are not approved, the contractor shall forthwith arrange to supply to the Engineer-in-Charge/QA Deptt. for his approval fresh samples complying with the specifications laid down in the contract. Engineer-in-Charge/QA Deptt. has powers to get such materials tested before approval.
- 14.3.0 The Engineer-in-Charge/ QA Deptt. shall have full powers to require removal of any or all of the materials brought to site by the Contractor which are not in accordance with the Contract specifications or do not conform in character or quality to the samples approved by him. In case of default on the part of the Contractor in removing rejected materials, the Engineer-in-Charge/ QA Deptt. shall be at liberty to have them removed by other means. The Engineer-in-Charge/QA Deptt. shall have full powers to procure other proper materials to be substituted for rejected materials and in the event of the Contractor refusing to comply, he may cause the same to be



supplied by other means. All costs, which may be incurred to attend upon such removal and or substitution, shall be borne by the Contractor.

14.4.0 The Contractor shall indemnify the Corporation, its representatives or employee of the Corporation against any action claim or proceeding relating to infringement or use of any patent or design or any alleged patent or design rights and shall pay any royalties or other charges which may be payable in respect of any article or material or part thereof included in the contract. In the event of any claim being made or action being brought against the Corporation or any agent, servant or employee of the Corporation in respect of any such matters as aforesaid, the Contractor shall immediately be notified thereof. Provided that such indemnity shall not apply when such infringement has taken place in complying with the specific directions issued by the Corporation, but the Contractor shall pay royalties or other charges payable in respect of any such use, the amount so paid being reimbursed to the Contractor only if the use was the result of any drawing and/or specifications issued after submission of the tender.

14.5.0 The Engineer-in-Charge/QA Deptt. shall be entitled to have tests carried out as specified in the contract for any materials supplied by the Contractor. The tests shall be conducted at the Corporation's laboratory or at any reputed lab, if the facility is not available at Corporation's lab. All the testing charges shall be borne by the contractor for the testing of materials which are procured by the contractor at his own cost. The unit rate of items shall be deemed inclusive of cost of testing of such materials.

14.6.0 In addition, the Contractor shall perform/submit at his own cost such test samples as may be required by the Engineer-in-Charge out of the materials issued by the Corporation, except for the cost of materials used in such tests/samples.

14.7.0 Stock Register to be maintained at site by the Contractor:

For all the materials like Steel, Cement etc. brought to the site for use in the work by the Contractor as per terms of contract; Stock Register for each item shall be maintained at site by the Contractor. The Stock Register should indicate the daily receipt, issue (consumption) and current stock at any point of time. Engineer-in-Charge or his representative can check the Stock Registers at site any time. The physical stock vis a vis the closing stock as per Stock Register shall be matched.

15.0.0- MATERIALS TO BE SUPPLIED BY THE CORPORATION:

15.01.0- SCOPE OF "OWNER ISSUE MATERIALS"

15.01.01-Corporation may issue cement (Portland, Pozzolana and slag) alongwith cement bag and steel (Mild steel Round Bars as well as high yield cold deformed bars) and structural steel Angles, joists, channels, plain and chequered plate and pipes to the contractor (**For details refer special conditions of contract**). If such materials will be issued the same shall be provided by the owner from owner's stores at Project Site for the works to be executed at the site "FREE OF COST" to the Contractor for incorporating in the works. All further responsibility of transportation, stocking preservation accounting etc., shall be that of the contractor.

15.01.02-Following material shall have to be arranged by contractor within his quoted rates/bid prices:

- (a) Cement (Portland, Pozzolana or slag) required for items of work other than those for which it has been specified to be issued as free of cost by the owner, in the schedule of item.
- (b) Mild steel round bars as well as high yield deformed bars required for items of work other than for which it has been specified, to be issued as free of cost by the owner, in the scheduled of items.
- (c) Structural steel (Angles, Joist, Channel, Plain and Chequered plates and pipes etc.) required for item of work other than for which it has been specified, to be issued as free of cost by the owner, in the schedule of items.
- (d) Other materials, including special reinforcement and structural steel, square bars, flats, white and special cement, cement adhesives etc.

15.01.03- The Contractor shall use the free of cost issued cement, reinforcement steel & structural steel only in the permanent works. Unless otherwise specifically agreed to by the Owner, Cement and steel required for the enabling works such as contractor's staff/labour colony, office and storage sheds construction, temporary staging, scaffolding, platform etc. shall not be issued by the Owner and shall be arranged by the Contractor at his own cost.

15.01.04- The quoted rates or price (s) indicated shall not take into account the cost of free issue/owner issue materials as indentified above but should include cost of any wastages not allowed by



Owner, carriage, loading, unloading, weighment, storage, testing, joining, mixing, placing, cutting, binding, assembly, welding etc. and any other activity as may be required till its acceptance upto incorporation in the works or its return to the Owner's stores.

15.01.05- Cement (Portland, Pozzolana or slag), Reinforcement steel (Mild steel, round bars as well as high Structural yield deformed bars) and structural steel (Angles, Joists, Channels, plain and chequered plate and pipes) shall be issued free of cost to the Contractor for incorporation into those items of works, where it has been specified to be so issued.

15.01.06 In case of any delay in arranging the materials or delay on account of non availability of any of the materials to be issued by the Corporation, the same shall not entail any kind of cost compensation or financial claim against the Corporation and the contractor shall only be entitled to suitable time extension as deemed reasonable and appropriate by EIC.

15.02.0-PROCEDURE FOR ISSUE, STACKING, ACCOUNTING AND RECONCILIATION OF OWNER ISSUED MATERIAL

15.02.01- For the purpose of quantity, accounting of materials, weights and classification of wastage of various categories, provisions of the following clauses shall be applicable. The owner, however, may at its discretion issue the materials in each lot on the basis of actual weighment also. It should be clearly understood that irrespective of the METHODOLOGY adopted for issuing the materials, the Contractor shall have no claim whatsoever, on account of the time and cost involved in issue, accounting stacking, transporting, loading and unloading reconciliation etc. of the owner issue material.

15.02.02- AVAILABILITY:

(a) All materials to be issued by the owner shall be collected by the Contractor from the Corporation's store in such conditions and in such length/ weight/ size as are available in stock or as received from manufactures.

(b) If at the time of actual execution a particular section is not available, then with the prior approval of the Engineer-in-Charge, alternate section may be used. Only increase in the weight of steel on account of EIC's authorised substitution shall be to the Owners account and the Contractor shall have no other claim whatsoever on account of such substitution.

(c) Unless otherwise provided, the contractor shall in no case be entitled to any compensation or damage on account of any delay in supply or non supply thereof of all or any such materials.

15.02.03- For issue of free of cost "Owner Issue Materials" from Corporation's stores the following procedure shall apply:

(a) Cement- Cement will be issued on the basis of approved construction drawings, allowing for wastage as specified elsewhere in this document considering each cement bag of 50 kg.

(b) Reinforcement Steel, Mild Steel and high yield deformed bars-

Reinforcement steel shall be issued to the contractor from the project stores on the basis of construction drawings/approved bar bending schedules allowing for wastage as specified elsewhere in the document. The reinforcement steel shall be issued to the Contractor on the basis of weight, such weight being calculated on the following basis:

(i) All issues of reinforcement steel above 12 mm dia. shall be made on the basis of "Section weight "as per ISI hand book for structural engineers.

(ii) All issues of reinforcement steel upto and including 12mm dia. (in coil or straight length) shall be made in terms of actual weighment done.

(iii) The actual weighment shall be done on weighing equipment available at the project site or in the event of non-availability of the weighing equipment, on the basis of random length/Bundle weights as decided by the Engineer-in-Charge and jointly recorded in a register on day to day basis or each indent basis. The reinforcement steel shall be issued to the contractor in such diameters and length which are presently rolled in the country or as available in project stores.

(c) Structural Steel

Structural steel shall be issued to the Contractor from the project stores on the basis of fabrication drags/approved design allowing for wastage as specified elsewhere in this document. The structural steel shall be issued to the contractor on the basis of weight, such weights being calculated on the following basis.



- (i) All issues of structural steel above 35 mm. width or above 6mm. thickness shall be made on the basis of "Section weight" as per IS:808.
- (ii) All issue of Structural steel upto and including 35 mm. and thickness upto & including 6 mm. shall be made in terms of actual weightment done.
- (iii) The actual weightment shall be done on weighing equipment available at the project site or in the event of non-availability of weightment equipment, on the basis of random length/bundle weights as decided by the Engineer-in-Charge and jointly recorded in a register on day to day basis or each indent basis.
- (iv) The structural steel shall be issued to the Contractor in such sections and length which are presently rolled in the country or as available in the project stores.
- (v) In case of issue of those sections for which unit weight is not given in ISI Hand Book, unit weight as furnished by supplier shall be considered. In absence of any unit weight furnished by the supplier a representative unit weight shall be found out at site by Engineer-in-Charge by selecting raw sections and actually weighing them.
- (i) Unsheared plates- As specified in technical specification.

(d) Schedule for Material & Equipment

For the materials which the Corporation has agreed to issue free of cost to the Contractor, contractor shall give a reasonable notice in writing of his requirement to the Engineer-in-Charge in accordance with agreed phased programme.

15.02.04- The Contractor shall indicate the following details to the Engineer-in-charge fortnightly for free issue material:

- (i) Total quantity required as per the contract
- (ii) Cumulative quantity issued prior to the subject requisition.
- (iii) Available stock with the Contractor.
- (iv) Quantity required together with the details of the consumption proposed.

15.02.05- For each consignment of materials from the Owners, the Contractor shall give proper acknowledgement in writing for the receipt thereof. The acknowledgement shall indicate full particulars of the quantities, section, sizes, grade and quality and such other information as are normally required by the stores.

15.02.06- Should there be any damage or distortion of material in transit, the contractor shall immediately report the matter to Engineer-in-Charge.

15.02.07- STACKING & STORAGE:

1. Cement-

Godown of suitable storage capacity shall be constructed by the Contractor at his own cost as per specifications approved by Engineer-in-Charge. Normally two months' maximum requirement capacity needs to be provided unless otherwise instructed by Engineer-in-Charge. The cement in bags shall be stacked well away from the walls and insulated from floor to avoid contact with moisture. The cement in bags shall be in easily countable stacks and to facilitate removal for use on "First in First out" basis, Cement bags shall be gently handled to avoid leakage from the bags. Cement stored for a period beyond 90 days shall be tested before use at Contractor's cost. The cement go down shall have a provision for locking, which shall be locked by the Contractor and the owner may also choose to put a joint stock. The Engineer-in-Charge may refuse issue of cement, if storage as indicated above is not available with the Contractor.

2. Steel-

Reinforcement steel and structural steel shall be stored and stacked in such a manner so as to facilitate easy identification, removal etc. The Contractor shall provide necessary drainage at his own cost as per direction of the Engineer-in-Charge.

15.02.08- ACCOUNTING

The Contractor shall maintain a proper store account for all the owner issue material and shall give a copy of the monthly statement of such accounts to the Owner.

(a) RECONCILIATION OF RECORDS

- (i) The reconciliation between the records as directed by Engineer-in-Charge of the actual consumption and the theoretical consumption requirements shall be done on quarterly basis or earlier as desired by Engineer-in-Charge and at 100% of the value of work. Any cases of discrepancies between issue, receipt and consumption should feature boldly in monthly



- report submitted on 1st day of succeeding month. The closing balance as per the account should be physically verified periodically at time of reconciliation jointly by an authorized representative of the contractor and the Engineer-in-Charge. The Engineer-in-Charge shall take suitable action where he notices high/ low consumption with respect to theoretical consumption and keep a record of the reason for recovery on this account at penal rates specified herein.
- (ii) At the time of submission of bills the Contractor shall properly account for the material issued to him as specified herein to the satisfaction of Engineer-in-Charge, certifying that balance material are available with the contractor's custody at site.
 - (b) The owner may depute his authorized officer or a team of officers to Visit the contractor's godowns and check the stocks for quality and quantity, method of stacking etc.
 - (c) The accounts of "Owner Issue Materials" shall be reconciled and the outcome of such reconciliation shall be jointly signed by the authorized representatives of the owner and the contractor. The Proforma for such "Owner Issue Materials" Account Reconciliation shall be as per Proforma enclosed at **Annexure-N**.
 - (d) The Contractor shall solely be responsible for the safety, quality and quantity of the material after it is issued by the owner.
 - (e) At any point of time, materials outstanding as unaccounted for shall be limited to ten percent (10%) by value of the total security given by the contractor for the materials unless otherwise permitted in writing by Engineer-in-Charge.
 - (f) All wastages/scrap of materials (including metaling scrap, wastage, unusable, scrap cut pieces and usable cut pieces but excluding empty cement bags) as well as the unused materials including sweep cement shall be promptly returned by the Contractor to the owner at the owner's project stores/stockyard and a receipt obtained for material accounting purposes. No compensation shall be payable by the owner to the Contractor for returning these materials
 - (g) Owner issue materials shall not under any circumstances whatsoever be taken out of the work site unless otherwise permitted by the head of the project.
 - (h) Each time when there is a change in the stock of cement in contractor's godown due to issue for re-consumption or due to receipt from owner's store, the same shall be jointly signed by the authorised representative of the owner and the contractor in the register maintained for the purpose.
 - (i) The limit for the maximum quantity of "owner issue materials" that could be with the contractor at any point of time when work is in progress (excluding what has already been incorporated in the works) may not exceed 2 months' consumption.
 - (j) The quantum of materials to be issued by owner shall be finally decided by Engineer-in-Charge based on the requirement for execution of work.

15.03.0 CONSUMPTION RECONCILIATION

- (a) The reference drawings for actual material consumption to be used for the purpose for reconciliation shall be drawings prepared by the owner and such other drawings approved by the owner. This shall also include the bar bending schedule prepared by the contractor and approved by the owner.
- (b) If as a result of "stage" of "three monthly" reconciliation mentioned above, it is found that actual consumption (including all wastages/scrap etc.) exceeds the theoretical consumption envisaged under the contract, the cost of such materials shall be recovered at penal rates identified in the succeeding clauses from the contractor's progressive bills or recovered otherwise as provided for in the contract.
- (c) If the free of cost owner issued materials have been used in item of work other than for which it is issued then the cost of such material used shall be recovered at the maximum penal rates identified for the corresponding item in the succeeding clause from the contractor's progressive bills.

15.03.01- CEMENT CONSUMPTION:

- (A) The calculation for theoretical consumption of cement shall be based on following :
 - (i) For design mix concrete, as per approved design mix.
 - (ii) For nominal mix concrete work, as per minimum cement as specified or as approved by Engineer-in-Charge.



(iii) For item of works, where volume, mix is permitted in writing by the Corporation e.g. masonry works, plaster and other miscellaneous items, the cement consumption shall be normally governed by the “statement of cement consumption” attached to Delhi schedule of Rates of CPWD-DSR "unless otherwise specified in the specifications or the drawings or contract or mutually agreed to by the Engineer-in-Charge and the contractor.

(B) (i) Actual consumption = (issue) – (surplus)

(ii) Surplus = sealed bags having usable cement (weight to be calculated considering each bag weight as 50 kg).

(C) The quantum of free of cost issued cement and deterrent rates for the recovery for excess consumption, over and above such free of cost quantities shall be recovered by the owner worked out on the following basis:

SI.No.	CEMENT	BASIS OF ISSUE AND RECOVERY
1	2	3
C-0	Theoretical consumption without considering any wastage or loss	Free
C-i	Actual consumption being limited to plus three percent of aforesaid theoretical consumption combine.	Free
C-ii	Actual consumption beyond three percent of aforesaid theoretical consumption.	Recovery of 2 times the landed cost at stores as applicable at the time of recovery, Sale Tax shall be recovered extra as applicable.

15.03.02- REINFORCEMENT STEEL CONSUMPTION

(A) The theoretical consumption of various sections and/or diameter of reinforcement steel shall be based on approved construction drawing and bar bending schedule, weights shall be calculated considering the sectional weights as per ISI hand book for structural engineers, No extra cost shall be payable to the contractor for any deviation in weights for the two different procedures adopted for issue and calculation of the theoretical consumption.

(B) (i) Actual consumption = (issue) – (surplus)

(ii) Surplus = untampered lengths of bars and cut pieces of 3 mtrs above length (wt. on the basis of its sectional weights)

(iii) Wastage = (Actual consumption - theoretical consumption)

Wastage is further classified as cut pieces (pieces of lengths less than 3 m and melting scrap) and measured as per actual weightment for scrap and by sectional weight basis for cut pieces.

(C) The quantum of free of cost issued reinforcement steel and deterrent rates for the recovery for excess consumption, if any over and above such free of cost issued quantities shall be recovered by owner worked out on the following basis:

SI.No.	Reinforcement steel	Basis of issue and recovery rates
1	2	3
1	Theoretical consumption (without considering any wastage scrap or loss)	Free
2	Wastage limited to plus three percent (+ 3%) of aforesaid theoretical consumption (cut-piece+ scrap to be returned to owner).	Free
3	Wastage beyond 3%	Recovery at two times of the landed cost at stores as applicable at the time of recovery plus sales tax.



(D) Entire quantity of wastages as mentioned above shall be returned by the Contractor to the Owner's store without any-extra cost. Credit shall be given to contractor for the cut piece and scrap returned at the following rates :

- (i) Cut pieces and scrap returned upto 3% of theoretical consumption – Free
(ii) Cut pieces and scrap returned beyond 3% of theoretical consumption – as follows

For cut pieces	For scrap
At the rate of landed cost at stores	At – 75% rate of landed cost at stores.

- (E) For any material issued by the owner to the contractor free of cost, and which is not accounted for by the Contractor, then the recovery for such material shall be effected at the penal rates specified at SI.No.3 above.
- (F) For non return by the Contractor to Owner Store, of any quantity of wastage steel calculated under SI.No.2 above, the recovery for such less return of steel shall be effected at the penal rates as specified at SI.No.3 above.

15.03.03- STRUCTURAL STEEL CONSUMPTION

- (a) During execution or after completion of work or termination of the contract, the theoretical quantity of steel used in fabrication shall be calculated on the basis of weights approved for payment in the shop drawings/shop bill/drawings office. List of material duly taking also into account the modifications approved during fabrication by the Engineer-in-Charge.
- (b) The weight will be worked out on the basis of unit weights given in IS:808. In case of those sections for which weight is not given in IS:808, unit weight as adopted at the time of issue shall be considered for the purpose of calculation of weight.
- (c) (i) Actual consumption = (issue) – (Surplus steel)
(ii) Surplus steel = untampered steel pieces.
(iii) Wastage = Actual consumption – theoretical consumption.
- (d) Wastage is further classified as cut pieces, scrap and rolling/melting scrap.
- (i) Piece of 3m or longer than 3 Meters for RSJ's channels, angles, flats, pipes, and for plates equal or more than 1500 sq. cm, in area with a minimum width of 15 cm shall be termed as cut pieces and stacked separately. The cut pieces of plates returned shall be rectangular in shape.
- (ii) Pieces shorter than 3 meters for RSJ's, channels, angles, flats, pipes, and for plates less than 1500 sq. cm. in area and/or less than 15 cm in width shall be classified as scrap and stacked separately.
- (iii) Rolling/melting scrap cutting edges/pieces shorter than 100 mm for RSJ's channels, angles, pipes and flats and for plates less than 40 mm in width and/or less than 3 kg. in weight shall be classified as Rolling/melting scrap.
- (e) Invisible wastage due to gas cutting straightening of edges etc. shall be taken as 0.5% and shall be free.
- (f) (i) Surplus mentioned in sub-Para d, (ii) above shall be returned to the Engineer-in-Charge at a place as directed by him, Credit for quantity of such material shall be given at full weight. The return of surplus untampered pieces by Contractor shall be on the basis of weight arrived at in the same manner as for the issue of material.
(ii) The Corporation will take back the cut pieces and scrap mentioned in sub-Para d (i) and (ii) respectively. The return of cut pieces mentioned in sub-Para (i) above by the contractor shall be on the basis of weight arrived at in the same manner as for the issue of materials, normally on the basis of sectional unit weight at the time of issue. The return of scrap mentioned in sub-Para d (ii) above by the contractor shall be on the basis of actual weight.
(iii) The Contractor will not be allowed to take away melting scrap. These shall be returned by the Contractor to the Corporation's store without any extra charge. However, no credit shall be given for the melting/rolling scrap returned as the Contractor's quoted rate is deemed to include various wastages mentioned above. The Contractor shall not be entitled to cartage and incidental charges for returning the surplus, cut pieces and scrap materials to the place as directed by the Engineer-in-Charge.
- (g) In case the actual consumption is more than the prescribed limits over the theoretical quantities, the recovery shall be as follows :



SI. No.	Consumption of structural Steel (Plates & rolled sections)	Basis of issue and recovery rates
1	2	3
S-0	Theoretical consumption (without considering any wastage, scrap or loss as per specifications and drawings.	Free Issue
S-I	Consumption over S-0 above upto 3% of the aforesaid Theoretical consumption for all rolled sections & sheared plates and upto 4% for unshared plates. (All wastage steel quantities to be returned to Owner)	Free Issue
S-II	Excess consumption beyond S-I rolled sections & sheared plates, and 8% and unshared plates (All wastages steel quantities to be returned to Owner)	Recovery at the rate of landed cost at stores as applicable at the time of recovery for structural & plates plus Sales tax as applicable + 25%
S-III	Excess consumption beyond S-II (All wastage steel quantity to be returned to Owner)	Recovery at Three (3) time of rate of landed cost at stores as applicable at the time of recovery for structural & plates plus sales tax as applicable.

- (h) Entire quantity or wastage as mentioned above shall be returned by the contractor to the owner's store. The credit for return of such steel shall be given as mentioned below:
- (i) For upto 3% of theoretical consumption for all rolled sections and sheared plates - Nil
 - (ii) For upto 4% of theoretical consumption for all rolled sections and sheared plates - Nil
 - (iii) Cut pieces and scrap returned beyond 3% for rolled sections & shear plates-
 - (a) For cut pieces – At the rate of landed cost at stores.
 - (b) For scrap – At 75% of the rates of landed cost at stores.
 - (iv) Cut pieces and scrap returned beyond 4% for unshared plates –
 - (a) For cut pieces – At the rates of landed cost at stores.
 - (b) For scrap – At 75% of the rates of landed cost at stores.
 - (i) For any material issued by the owner to contractor free of cost which is not accounted for by contractor to the owner, then the recovery, for such material shall be effected at the penal rates specified under S-III above.
 - (ii) The wastage/scrap mentioned above shall deemed to mean and include all left over materials after each stage completion of the work as per specification and drawings, including melting scrap, other unusable and useful cut pieces. All such wastage shall be accounted for by the contractor and returned to the owner, except the loss due to structural steel only. For non-return of any quantity of wastage steel as per S-I above by the Contractor to the owner's store, the recovery for such less return shall be effected at the penal rates specified in S-II above.

15.04.0- SURETY FOR MATERIALS :

15.05.0- Apart from other required security, watch & ward etc., the cost of “Owner Issue Material” shall be secured by Indemnity Bond to be furnished by the Contractor in prescribed Performa, for the maximum quantity of various owner Issue Materials, which can be in custody with the contractor at any point of time, as per provisions laid herein. The value of the Indemnity Bond shall be calculated for quantities of material to be consumed in 3 months time on landed cost basis. The validity of such surety i.e. Indemnity Bond shall be kept initially till 12 months after the scheduled date of completion of work. Only upon acceptance of such surety, the material shall be issued.

15.04.02- If, at any stage, material in excess of the quantity envisaged as per Indemnity Bond are required by the Contractor, the same excess quantity can be issued only after the value of the Bond is correspondingly increased and or the contractor agrees to the deduction of amount of such excess quantities from his running bills under the contract.



15.04.03- **Insurance** – The material shall be insured by the contractor at his own cost for the cost of the material in the joint names of contractor and the owner.

15.05.00- QUALITY OF OWNER ISSUE MATERIAL:

15.05.01- CEMENT QUALITY:

Cement to be used for incorporation in the works normally shall be ordinary port- land cement or port land pozzolana cement (Grey conforming to IS:455/ Latest Edition) or Portland Pozzolana cement conforming to IS:1489 (Latest Edition) may be used in place of ordinary Portland cement but such a substitution shall be only with the prior approval of the Engineer-in-Charge. Contractor shall take adequate measures/precautions as to the use of cement as instructed by the Engineer-in-Charge while allowing such substitution, at no extra cost to the Owner.

15.05.02- REINFORCEMENT STEEL QUALITY:

Reinforcement steel of various diameters sections to be used for incorporation in the works shall conform to :

(a) Mild Steel Grade- I, IS:432 (Part-I)

(b) Cold, Twisted, High Yield strength deformed steel Bar IS:1786 (Latest edition)

(c) Rolled steel made from structural steel conforming to IS:226.

15.05.03- STRUCTURAL STEEL QUALITY:

Structural steel to be used for incorporation in the works shall be conforming to IS:226 and IS:2062 in available sections, thickness and width, will be issued by THDC in accordance with availability in stock or as received from manufacturers. Pipes shall conform to IS:1161.

15.06.00- OPTIMUM UTILISATION OF MATERIALS:

15.06.01-The contractor shall ensure that the materials issued by the Owner is utilised optimally. The wastages by way of leakage of cement from bags, off cuts in Reinforcement steel and structural steel is to be kept minimum.

15.06.02- Use of Sweep Cement:

The contractor shall use the "Sweep Cement" accumulated at its stores as directed by Engineer-in-Charge. Failing utilization within fifteen (15) days, it should be collected in bags and returned to owner's stores within one month of issue of applicable lot.

15.06.03- Utilisation of Reinforcement/ Structural Steel

Engineer-in-Charge shall direct the Contractor to utilise the suitable cut pieces without extra cost to THDC either by lapping, (in Reinforcement Steel), the required butt welding and/or splicing in structural Steel. The material required for joining such used steel shall be issued from off- cuts by the Corporation and upon proper utilization weight shall be considered for account.

15.06.04- The Engineer-in-Charge can direct the contractor to use without any extra cost to owner, cut pieces generated by other contractors working in project. These cut pieces shall have to be lifted either from the project stores or from the fabrication yards of other contractors as per the directions of the Engineer-in-Charge. The issue of such cut pieces shall be on the same basis of the issue of fresh steel from the project store. All other stipulations mentioned elsewhere in the clause regarding wastage and excessive consumption of steel shall remain unchanged.

15.06.05- Flat will not be supplied by the Corporation. If flats are required for incorporation in any of item of the schedule of items for which the structural steel is a free issue material, then the same shall have to be cut from plates without any extra cost to owner. However, such plates used shall be reconciled as per reconciliation clause.

15.07.00- GENERAL

15.07.01- Empty cement bags

The issue of cement is inclusive of cement bags. The Contractor shall be issued cement alongwith cement bag and empty cement bags is not required to be returned at the Corporation's stores.

15.07.02- Transportation from Rail Head

The corporation may issue all the materials to be issued to the contractor under the contract, at its site stores or from nearest rail head or Rishikesh stores. In case the materials are issued at the nearest rail head or Rishikesh Stores, the cost of transportation only from such rail head or Rishikesh stores to the site as decided by Competent Authority will be borne by the Corporation. Loading and unloading charges will be borne by the contractor.

15.07.03- Other Materials



If after acceptance of the tender the contractor desires the corporation to supply any other materials, such materials may be supplied by the Corporation, if available, at terms to be fixed by the corporation. The corporation reserves the right not to issue any such materials. The non-issue of such materials will not entitle the contractor for any compensation whatsoever either in time or in cost.

- 15.07.04-** All materials issued to the contractor by the corporation for incorporation in the works, off cuts, wastages, scrap, other useful cut pieces, shall on completion or reconciliation or on fore closures of the works be returned by the Contractor at his expenses at the place of issue, after making due allowance for actual consumption, reasonable wear and tear and/or wastage. If the Contractor is required to deliver such material at a place other than the place of issue, he shall do so and the transportation charges from the site to such place, less the transportation charges which would have been incurred by the contractor had such materials been delivered at the place of issue, shall be borne by the corporation.
- 15.07.05-** Surplus materials returned by the Contractor shall be credited to him by the Engineer-in-Charge at quantity/weight and at rates not exceeding those at which these were originally issued to him after taking into consideration any deterioration or damage which may have been caused to the said materials while in the custody of the contractor.
- 15.07.06-** If on completion of works the contractor fails to return surplus materials out of those supplied by Corporation, then in addition to any other liability which Contractor would incur, the Engineer-in-Charge may, by written notice to the contractor, require him to pay within a fortnight of receipt of the notice for such unaccounted and unreturned surplus material at the max. of consumption penal rates.
- 15.07.07-** Materials required for the works, whether brought by the contractor or issued by the Corporation shall be stored by the contractor only at a place approved by Engineer-in-Charge. Storage and safe custody of material shall be the sole responsibility of the contractor.
- 15.07.08-** Corporation's officials concerned with the contract shall be entitled at any time to inspect and examine any materials intended to be used in or on the works, either on the site or at factory or workshop or other place (s), where such materials are assembled, fabricated, manufactured or at any place(s) where these are lying or from which these are being obtained and the Contractor shall give such facilities as may be required for such inspection and examination.
- 15.07.09-** All materials brought to the site shall become and remains the property of Corporation and shall not be removed off the site without the prior written approval of the Engineer-in-Charge. But, whenever the works are finally completed and advance if any, in respect of any such material is fully recovered, the contractor shall at his own expense forthwith remove from the site all his surplus material brought to site other than owner's material originally supplied by him.
- 15.07.10-** The provisions detailed herein above shall not in any way dilute the contractor's liabilities under the contract in any manner whatsoever.

16.0.0- TAXES DUTIES AND LEVIES ETC.

- (a) All charges on account of sales tax or any other tax or duty or levy, such as Octroi, Dharat, Royalty, Terminal Tax, Toll tax etc. on all material, including petrol, oil and lubricants (and increase, if any on these during the currency of the contract) that the contractor has to purchase for the performance of the contract, from any source be borne by the contractor (excluding materials supplied by THDCIL) and the Corporation will not entertain any claim or compensation whatsoever, in this regard. The rates quoted by the Contractor shall be deemed to be inclusive of all such aforesaid taxes, duties, levies, royalties etc. and any increase thereon.
- (b) Contract tax, turnover tax or any similar tax, if applicable, is to be borne by the Contractor. The corporation will not entertain any deviation whatsoever in this respect.
- (c) Stamp duty, wherever applicable, in any form is to be borne by the Contractor.
- (d) The Contractor shall pay all tollage and other royalties, rent and other payments or compensation (if any on getting stone, sand, gravel, clay or any other materials) required for execution of works.
- (e) However, if a New Tax or Duty or Levy (other than the existing on the date of opening of the tender) is imposed under a statute or law during the currency of the contract and the contractor become liable to and actually pays the same for this contract, the contractor shall immediately inform the Corporation in this regard. The Corporation will examine and reimburse the same to the contractor on submission of documentary evidences in support of the payment made as per



new law only for the transactions between the contractor and the owner. However, no claim shall be entertained by THDC for any liability in this respect for the transactions between contractors and his suppliers or sub- contractors.

- (f) The contractor shall provide documentary evidence to the owner of all taxes, levies paid for completion of the awarded work for which contractor is liable to pay, if required.

17.0.0- Labour

17.1.0- The contractor shall employ labour in sufficient numbers to maintain the required rate of progress and of quality to ensure workmanship of the degree specified in the Contract and to the satisfaction of the Engineer-in-Charge. The Contractor shall not employ in connection with the works any person who has not completed his fifteen years of age.

17.2.0- The contractor shall furnish to the Engineer-in- Charge at weekly intervals or as desired by Engineer-in-Charge a distribution return of the number and description by trade of the people employed on the works. The Contractor shall also submit on the 4th and 19th of every month to the Engineer-in-Charge a true statement showing in respect of the second half of the preceding month and for first half of the current month (i) the accidents that occurred during the same fortnight showing the circumstances under which they happened and the extent or damage and injury caused by them and (ii) the number of female workers who have been allowed maternity Benefit as provided in the Maternity Benefit Act., 1961 or rules made thereunder and the amount paid to them.

17.3.0- The Contractor shall pay to the labour employed by him either directly or through subcontractor wages not less than fair wages as defined in the Contractor Labour Regulations.

17.4.0- The Contractor shall in respect of labour employed by him or his sub-contractors comply with or cause to be complied with the Contractors Labour Regulations in regard to all matters provided therein.

- (j) The Contractor shall at his own expense comply with upto date amendments, if any and other law relating thereto and rules made thereof from time to time. The acts mentioned herein are only illustrative and not exhaustive.

a) Payment of Wages Act, 1936

b) Minimum Wages Act, 1948

c) Employer's Liability Act, 1938

d) Workmen's Compensation Act, 1923

e) Industrial Dispute Act, 1947

f) Maternity Benefit Act, 1961

g) Mines Act, 1952

h) Contract Labour Regulation Act, 1970

i) Industrial Employment Act, 1946

j) Personal injuries (Compensation Insurance Act.)

k) Payment of Bonus Act, 1965

l) U.P. Contract Labour (Regulation & Abolition) Rules, 1975

m) Provident Fund Act.

n) EPF Code No. under the Employees Provident Funds and Miscellaneous Provision Act 1952.

o) ESI Code No. under Employees State Insurance Act, 1948.

p) Building & other construction workers (Regulation of Employment and conditions of services) Act, 1996 along with Rules, 1996 of Cess Act and Rules.

- (ii) The Contractor shall be liable to pay his contribution and the employee contribution to the state insurance & regional provident fund commissioner Scheme in respect of all labour employed by him for the execution of the contract, in accordance with the provision of "The employees State Insurance Act, 1948 as amended from time to time. In case the contractor fails to submit full details of his account of labour employed and the contribution payable, the Engineer-in-Charge shall recover from the running bills of Contractor an amount of contribution as assessed by him. The amount so recovered shall be adjusted against the actual contribution payable for Employee State Insurance.

17.5.0- Contractor shall indicate their Sales Tax No. & P.F. code no issued by concerned authorities.

17.6.0- The Engineer-in-charge shall, on report having been made by an inspection officer as defined in the Contractors Labour Regulation, have the power to deduct from the money due to the



contractor any sum required or estimated to be required for making good the loss suffered by a worker or workers by reason of non-fulfillment of the Conditions of the Contract for the benefit of workers, non-payment of wages or of deductions made from his or their wages which are not justified by the terms of the contract or non-observance of the said Contractors Labour Regulations.

17.7.0- The Contractor, shall indemnify the Corporation against any payments to be made under and for observance of the Regulations aforesaid without prejudice to his right to claim indemnity from his sub-contractor.

17.8.0- In the event of the Contractor committing a default or breach of any of the provisions of the aforesaid Contractors Labour Regulations as amended from time to time or furnishing any information or submitting or filling any Form/Register/Slip under the provisions of these Regulations which is materially incorrect, then on the report of the inspection officers as defined in the Contractors Labour Regulations the contractor shall without prejudice to any other liability pay to the corporation a sum as demanded under the contractor's default containing in this respect, the liquidated damages may be enhanced to Rs. 50.00 per day for each day of default subject to maximum of ten percent of the estimated cost of the Works put to tender. The Engineer-in-Charge shall deduct such amount from bills or security deposit of the Contractor and credit the same to the Welfare Fund constituted under Regulation.

17.9.0- Model Rules for Labour Welfare:

The contractor shall at his own expenses comply with or cause to be complied with Model Rules for Labour as appended to this Conditions or rules framed by Government from time to time for the protection of health and for making sanitary arrangements for workers employed directly or indirectly on the works. In case the contractor fails to make arrangement as aforesaid, the Engineer-in-Charge shall be entitled to do so and recover the cost thereof from the Contractor. But this will not absolve the Contractor of his responsibility or other wise thereof.

17.10.0- Safety Code:

The Contractor shall at his own expense make arrangement for the safety provision as appended to this G.C.C. or as required by the Engineer-in-Charge, in respect of all labour directly or indirectly employed for performance of the works and shall provide all facilities in connection therewith. In case the Contractor fails to make arrangements and provide necessary facilities as aforesaid, the Engineer-in-Charge shall be entitled to do so and recover the cost thereof from the contractor. But this will not absolve the Contractor of his responsibility or otherwise thereof.

17.11.0- Failure to comply with model Rules for Labour Welfare, and to grant of maternity benefits to female workers shall make the contractor liable to pay damage as imposed by Labour Department/Court for each default. The decision of the Engineer-in-Charge in such matters based on reports from the inspecting Officers as defined in the Contractor's Labour Regulations as appended to this G.C.C. shall be final and binding and deduction for recovery of such damages may be made from any amount payable to the contractor.

18.0.0- Permission for Contractor to enter on/take Possession of the site:

The contractor shall not be permitted to enter on (other than for inspection purposes) or take possession of the site until instructed to do so by the Engineer-in-Charge in writing. The portion of the site to be occupied by contractor shall be defined/or marked on the site plan failing which these shall be indicated by the Engineer-in-charge at site and the contractor shall on no account be allowed to extend his operations beyond these areas. The contractor may be allotted some area if specified by the contractor in their tender about their requirement and agreed by THDC near the work site or elsewhere by Engineer-in-Charge for construction of fields office(s), Staff Colony, workshop stores etc. The Contractor at his own cost shall provide and maintain pathways, roads (including leveling and dressing if required) erect temporary structures for storage shed/office/residence etc. including temporary fences guards bridge as may be necessary for the execution of preliminary, enabling and ancillary works with the approval of Engineer-in-charge. The site is to be handed over back to Engineer-in-Charge or his representative. No payment or claim for above will be entertained by the Corporation. In respect of any land allotted to the contractor for purposes of or in connection with the contract, the contractor shall be a licensee subject to the following and such other terms and conditions as may be imposed by licenser.



- (i) That he shall pay a nominal license fee as applicable (**For details refer Special Conditions of Contract.**) per year or part of a year for use and occupation in respect of each and every separate areas of land allotted to him.
- (ii) That such use or occupation shall not confer any right of tenancy of the land to the contractor.
- (iii) That the contractor shall be liable to vacate the land on demand by the Engineer-in-charge.
- (iv) That the Contractor shall have no right to any construction over this land without the written permission of the Engineer-in-Charge. In case, he is allowed to construct any structure he shall have to demolish and clear the same before handing over the completed work unless agreed to the contrary.
- (v) That possession of site or other lands by the contractor in connection with the contract shall not be deemed to confer on him any right or interest in or over the land or possession thereof.

18.1.0- The contractor shall provide, if necessary or if required on the site, all temporary access thereto and shall alter, adapt and maintain the same as required from time to time and shall take up to and clear them always as and when no longer required and as and when ordered by the Engineer-in-Charge and make good all damage done to the Site.

19.0.0- SETTING OUT THE WORKS:

19.1.0- The Engineer-in-Charge shall supply dimensioned drawings, levels and other information necessary to enable the Contractor to set out the Works and the Contractor shall set out the works and be responsible for the accuracy of the same. He shall amend at his own cost and to the satisfaction of the Engineer-in-Charge any error found at any stage which may arise through inaccurate setting out. The Contractor shall protect and preserve all bench marks used in setting out the Works till end of the Defects Liability Period unless the Engineer-in-Charge directs their earlier removal.

19.2.0- The contractor shall extend full, assistance at his own cost for checking accuracy of already set out works. The checking of setting out any time and grade by Engineer-in-Charge shall not in any way relieve the contractor of his responsibility for the correctness of laid out works.

20.0.0- SITE DRAINAGE:

All water which may accumulate on the site during the progress of the works, or in trenches and excavation, from other than the excepted Risks shall be removed from the site to the satisfaction of the Engineer-in-Charge and at the Contractor's expenses.

21.0.0- NUISANCE:

The contractor shall not at any time do, cause or permit any nuisance on Site or do anything which shall cause unnecessary disturbance or inconvenience to owners, tenants or occupiers of other proprietor near the Site and to the public generally.

22.0.0 MATERIALS OBTAINED FROM EXCAVATION:

Materials of any kind obtained from excavation on the Site shall remain the property of the Corporation direct.

23.0.0 TREASURE, TROVE, FOSSILE, ETC.

All fossils, coins, articles of value or antiquity and structures and other remains or things of geological or archeological interest discovered on the Site shall be the absolute property of the Corporation and the Contractor shall take reasonable precautions to prevent his workmen or any other person from removing or damaging any such article or thing and shall immediately upon discovery thereof and before removal acquaint the Engineer-in-Charge with such discovery and carry out as per the Engineer-in-Charge's directions.

24.0.0 PROTECTION OF TREES:

Trees designated by the Engineer-in-Charge shall be protected from damage during the course of the Works and earth level within 1 meter of each such tree shall not be changed. Where necessary, such trees shall be protected by providing temporary fencing.

25.0.0 WATCHING AND LIGHTING:

The contractor shall provide and maintain at his own expenses all lights, guards, fencing and watching when and where necessary or required by the Engineer-in-Charge for the protection of the Works or for the safety and convenience of those employed on the works or the public.

26.0.0- CONTRACTOR'S SUPERVISION:

The Contractor shall either himself supervise the execution of the Works or shall appoint a competent agent approved by the Engineer-in-Charge. If the Contractor has himself not sufficient



knowledge and experience to be capable of receiving instructions or cannot give his full attention to the Works, the Contractor, shall at his own expense, employ as his accredited agent an engineer approved by the Engineer-in-Charge. Orders given to the contractor's agent shall be considered to have the same force if these had been given to the Contractor himself. If the Contractor fails to appoint a suitable agent as directed by the Engineer-in-Charge, the Engineer-in-Charge shall have full powers to suspend the execution of the Works until such date a suitable agent is appointed and the Contractor shall be held responsible for the delay so caused to the works.

27.0.0- INSPECTION AND APPROVAL:

All works embracing more than one process shall be subject to examination and approval at each stage thereof and the Contractor shall give due notice to the Engineer-in-Charge or his QA authorized representative when each stage is ready. In default of such notice, the Engineer-in-Charge shall be entitled to appraise the quality and extent thereof.

27.1.0 No work shall be covered up or put out of view without the approval of the Engineer-in-Charge or his QA authorised representative and the contractor shall afford full opportunity for examination at every stage and measurement of any work which is about to be covered up or put out of view and for examination of foundations before permanent work is placed thereon. The Contractor shall give due notice to the Engineer-in-Charge or his authorised representative whenever any such work or foundation is ready for examination and the Engineer-in-Charge or his QA representative shall without unreasonable delay unless he considers it unnecessary advise the Contractor accordingly, attend for the purpose of examining and measuring such work or of examining such foundations. In the event of the failure of the Contractor to give such notice he shall, if required by the Engineer-in-Charge, uncover such work at the contractor's expenses.

27.2.0- The Engineer-in-Charge or his representative or representative of QA Department shall have powers at any time to inspect and examine any part of the Works and the Contractor shall give such facilities as may be required for such inspection and examination.

28.0.0-DUTIES AND POWERS OF ENGINEER-IN-CHARGE AND ENGINEER IN-CHARGE'S REPRESENTATIVE:

28.0.1 The Engineer-in-charge shall carry out the duties specified in the contract which includes direction, supervision, and be in-charge of the works for purposes of this contract.

28.0.2 The Engineer-in-Charge may exercise the authority specified in or necessarily to be implied from the Contract, provided however, that if the Engineer-in-charge is required to obtain the specific approval from a Competent Authority other than him before exercising any such authority, he will do so and convey the decision to the Contractor.

28.0.3 The Engineer-in-Charge's Representative will be appointed by and be responsible to the Engineer-in-Charge and will carry out such duties and exercise such authority as may be delegated to him by the Engineer-in-charge under sub-clause 28.0.4 of this clause. He shall have no authority to relieve the Contractor of any of his duties or obligations under the Contract nor, except as expressly provided hereunder or elsewhere in the Contract, to order any work involving delay or any extra payment by the THDCIL nor to make any variation in the works.

28.0.4 The Engineer-in-charge may, from time to time, delegate to the Engineer-in-charge's representative any of the powers and authorities vested in the Engineer-in-charge and he may at any time revoke such delegation. Any communication issued by the Engineer-in-charge's representative to the contractor in accordance with such delegation shall have the same effect as though it had been issued by the Engineer-in-Charge. Provided that:

a) Any failure of the Engineer-in-Charge's representative to disapprove any work or materials shall not prejudice the authority of the Engineer-in-Charge thereafter to disapprove such work or materials and to give instructions for the removal or for the rectification thereof.

b) If the Contractor questions any communication of the Engineer-in-Charge's representative, he may refer the matter to the Engineer-in-Charge who will confirm, reverse or vary the contents of such communication.

28.0.5 The Engineer-in-Charge or the Engineer-in-Charge's Representative may appoint any number of persons to assist the Engineer-in-Charge's representative in the carrying out of his duties. Such assistants shall have no authority to issue any instructions to the Contractor save in so far as such instructions may be necessary to enable them to carryout their duties and to secure their acceptance of materials, plant, equipment and machinery or workmanship as being in accordance



with the Contract, and any instructions given by any of them for those purposes shall be deemed to have been given by the Engineer-in-Charge's representative.

- 28.0.6 Instructions given by the Engineer-in-Charge shall be in writing, provided that if for any reason the Engineer-in-Charge considers it necessary to give any such instruction orally, the Contractor shall comply with such instruction. Confirmation in writing of such oral instruction given by the Engineer-in-Charge, whether before or after the carrying out of the instruction, shall be deemed to be an instruction within the meaning of this sub-clause. Provided further that if the contractor, within seven days, confirms in writing to the Engineer-in-Charge any oral instructions of the Engineer-in-Charge and such confirmation is not contradicted in writing within seven days by the Engineer-in-Charge, it shall be deemed to be an instruction of the Engineer-in-Charge. The provisions of this sub-clause shall equally apply to instructions given by the Engineer-in-Charge's Representative and any assistants of the Engineer-in-Charge or the Engineer-in-Charge's Representative appointed pursuant to sub-clause 28.0.5 above.

29.0.0- REMOVAL OF WORKMEN:

The Contractor shall employ in and about the execution of the Works only such persons as are skilled and experienced in their several trades and the Engineer-in-Charge shall be at liberty to object to and require the Contractor to remove from the Works any person employed by the Contractor in or about the execution of the Works who in the opinion of the Engineer-in-Charge misconducts himself or is incompetent or negligent in the proper performance of his duties and such person shall not be again employed upon the Works without permission of the Engineer-in-Charge.

30.0.0- UNCOVERING AND MAKING GOOD:

The Contractor shall uncover any part of the Works and/or make openings in or through the same as the Engineer-in-Charge may from time to time direct for his verification and shall reinstate and make good such part to the satisfaction of the Engineer-in-Charge. If any such part has been covered up or put out of view after being approved by the Engineer-in-Charge and is subsequently found on uncovering to be executed in accordance with the Contract, the expenses of uncovering and/or making opening in or through, reinstating and making good the same shall be borne by the Corporation. In any other case all such expenses shall be borne by the Contractor.

31.0.0 WORK DURING NIGHT OR ON SUNDAYS AND HOLIDAYS:

Subject to any provisions to the contrary contained in the Contract, none of the permanent works shall be carried out during night or on Sundays or on authorized holidays without the permission in writing of the Engineer-in-Charge.

32.0.0- COMPLETION CERTIFICATE:

As soon as the work is completed, the contractor shall give notice of such completion to the Engineer-in-Charge and within thirty days of receipt of such notice the Engineer-in-Charge shall inspect the work and shall furnish the Contractor with a certificate of completion indicating (a) date of completion (b) defects to be rectified by the Contractor and/or (c) item for which payment shall be made at reduced rates. When separate periods of completion have been specified for items or groups of items, the Engineer-in-Charge shall issue separate completion certificates for such item or groups of items. No certificate of completion shall be issued nor shall the work be considered to be complete till the Contractor shall have removed from the premises on which the work has been executed all scaffolding, shed and surplus materials except such as are required for rectification of defects, rubbish and all huts and sanitary arrangements required for his workmen on the site in connection with the execution of the work, as shall have been erected by the Contractor or the workmen and cleaned all dirt from the part to buildings (s) in, upon or about which the work has been executed or of which he may have had possession for the purpose of the execution thereof, cleaned the floor, gutters and drains, eased doors and sashes, oiled locks and fastenings labeled keys clearly and handed them over to the Engineer-in-Charge and made the whole premises fit for immediate occupation or use to the satisfaction of the Engineer-in-Charge. If the Contractor shall fail to comply with any of the requirements of this clause as aforesaid, on or before the date of completion of the Works, the Engineer-in-Charge may at the expense of the Contractor fulfill such requirements and dispose of the scaffoldings, surplus materials and rubbish, etc. as he thinks fit and the Contractor shall have no claim in respect of any such scaffoldings or surplus materials except for any sum actually realized by the sale thereof less the



cost of fulfilling the requirements and any other amount that may be due from the Contractor. If the expense of fulfilling such requirements is more than the amount realized on such disposal as aforesaid, the Contractor shall forthwith on demand pay such excess.

32.2.0- If at any time before completion of the entire work, items or groups of items for which separate periods of completion have been specified, have been completed, the Engineer-in-Charge can take possession of any part or parts of the same (any such part (s) being hereinafter in this clause referred to as the relevant part) then notwithstanding anything expressed or implied elsewhere in this Contract:

- a) Within thirty days of the date of completion of such items or groups of items or of possession of the relevant part, Engineer-in-Charge shall issue completion certificate for the relevant part as in clause 32.1.0 above provided the contractor fulfils his obligations under the clause for the relevant part.
- b) The defects Liability period in respect of such items and the relevant part shall be deemed to have commenced from the certified date of completion of such items or the relevant part as the case may be.
- c) The Contractor may reduce the value insured by the full value of the completed items or relevant part as estimated by the Engineer-in-Charge for this purpose. This estimate shall be applicable for this purpose only and not for any other purposes.
- d) For the purposes of ascertaining compensation for delay under clause No.33.0 in respect of any period during which the works are not complete the relevant part will be deemed to form a separate items or group, with date of completion as given in the Contract or as extended and actual date of completion as certified by the Engineer-in-Charge under this clause.

33.0.0 – Compensation for Delay (Liquidated Damages):

33.1.0- If the contractor fails to maintain the required progress in term of time schedule to complete the work and clear the site on or before the scheduled date or extended date of completion, he shall without prejudice to any other right or remedy of the corporation on account of such breach, pay as liquidated damages, not as penalty, an amount equivalent to the value calculated at the rate of half percent (1/2%) of contract value for every week or part thereof for delay in execution of completion of work.

33.2.0- The total amount of liquidated Damages for delay in completion under the contract will be subject to a maximum of 10% (Ten percent) of the total contract value.

33.3.0- The amount of liquidated damages may be adjusted against any sum payable to the contractor or from any money(s) of contractor available with Corporation.

34.0.0-DEFECTS LIABILITY PERIOD:

34.1.0 The defect liability period for the work is 12 months from the date of completion of the work or as specified in SCC. The Contractor shall be responsible to make good and remedy at his own expense within such period, any defect which may develop or may be noticed before the expiry of the defect liability period from the certified date of completion and intimation of which has been sent to the Contractor within seven days of the expiry of the said period by a letter sent by hand delivery or by registered post.

35.0.0- CONTRACTOR'S LIABILITY AND INSURANCE:

35.1.0-From commencement to completion of the works, the contractor shall take full responsibility for the works or any part thereof and of taking precautions to prevent loss or damages and to minimize loss or damage to the greatest extent possible and shall be liable for any damage or loss that may happen to the Works or any part thereof and to all Corporation's T&P from any cause whatsoever and shall at his own cost repair and make good the same so that, at completion, the works and all Corporation's T&P shall be in good order and condition and in conformity in every respect within the requirements of the Contract and instructions of the Engineer-in-Charge.

35.2.0- In the event of any loss or damage to the works or any part thereof or to any T&P or to any material or articles at the site from any of the Excepted Risks the following provisions shall have effect:

- (a) The Contractor shall, as may be directed in writing by the Engineer-in-Charge remove from the Site any debris and so much of the works as shall have been damaged, take to the Corporation's stores such Corporations T&P, articles and/or materials as may be directed :



- (b) The contractor shall, as may directed in writing by the Engineer-in-Charge proceed with the erection and completion of the works under and in accordance with the provisions and conditions of the Contract : and
- (c) There will be added to the Contract sum the net amount due, ascertained in the same manner as for deviations, or as prescribed for payment in respect of the re-execution of the works lost or damaged, the replacement of any T&P and of any materials and articles lost or damaged but not incorporated in the Works on the day when the loss or damage occurred and the removal by the Contractor as provided above of Corporation's T&P articles and/or materials to the Corporation's store and of debris and damaged works referred to therein and the compensation paid by him under any law for the time being in force, to any workman employed by him for any injury caused to him, or to the workman's legal successors for loss of the workman's life.
- 35.3.0- PROVIDED always that the Contractor shall not be entitled to payment under the above provision in respect of so much loss or damage as has been occasioned by any failure on his part to perform his obligations under the Contract or not taking precautions to prevent loss or damage or minimize the amount of such loss or damage.
- 35.4.0- Where Corporation's building or a part thereof is rented by the Contractor he shall insure the entire building if the building or any part thereof is used by him for the purpose of storing or using materials of combustible nature as to which the decision of the Engineer-in-Charge shall be final and binding.
- 35.5.0- The Contractor shall indemnify and keep indemnified the Corporation all losses and claims for injuries or damage to any persons or any property whatsoever which may arise out of or in consequence of the construction and maintenance of Works and against all claims, demand proceedings, damages, costs, charges and expenses whatsoever in respect of or in relation thereto, PROVIDED always that nothing herein contained shall be deemed to render the Contractor liable for or in respect of or to indemnify the Corporation against any compensation of damage caused.
- 35.6.0- Before commencing execution of the work, the contractor shall, without in any way limiting his obligations and responsibilities under this condition, insure and maintain till works are completed and handed over to owner against any damage, loss or injury which may occur to any property, (excluding that of the corporation but including the Corporation's building rented by the Contractor wholly or in a part and any part of which is used by him for storing combustible materials), or to any person (including any employee of the Corporation) by or arising out of carrying out the Contract at his own cost.
- 35.7.0- The contractor or his representative shall take out, at his own expenses public liability with the following coverage:
- (i) Public liability limits for bodily injury or death not less than Rs. 1,00,000/- for one person and Rs. 2,00,000/- for each accident.
- (ii) Property liability for each accident not less than Rs. 1,00,000/-.
- The contractor shall at all times indemnify the Corporation against all claims, damages or compensation under the provisions of payment of wages Act, 1936, Minimum wages Act, 1948 Employer's Liability Act. 1938, the Workmen's compensation Act, 1923, industrial Disputes Act, 1947, and the Maternity Benefit Act, 1961 or any modification thereof or any other law relating thereto and rules made thereunder from time to time or as consequence of any accident or injury to any workman or other persons in or about the Works, whether in the employment of the contractor or not, save and except where such accident or injury has resulted from any act of the Corporation, his agents or servants, and also against all costs, charges and expenses of any suit, action or proceeding arising out of such accident or injury and against all sum or sums which may with the consent of and the contractor be paid to compromise or compound any claim, without limiting his obligations and liabilities as above provided, the contractor shall insure against all claims, damages or compensation payable under workman's Compensation Act, 1923 or any modification thereof or any other law relating thereto.
- 35.9.0- The aforesaid insurance policy/policies shall provide that they shall not be cancelled till Engineer-in-Charge has agreed to their cancellation in writing.



- 35.10.0- The Contractor shall ensure that similar insurance policies are taken out by his sub-contractor (if any) and shall be responsible for any claims or losses to the corporation resulting from their failure to obtain adequate insurance protection in connection thereof. The Contractor shall produce or cause to be produced by his sub-contractors (if any) as the case may be, the relevant policy or policies and premium as and when required by the Engineer-in-Charge.
- 35.11.0- The Contractor shall satisfy and prove to the Engineer-in-Charge from time to time that he and/or his sub-contractor has taken out all the insurance policies referred to above and has paid the necessary premiums for keeping the policies alive till expiry of the Defects Liability Period.
- 35.12.0- If the contractor and/or his sub-contractor (if any) referred to above or any other insurance which he/they may be required to effect under the terms of the Contract, then and in any such case the Corporation may, without being bound to, effect and keep in force any such insurance and pay such premium or premiums as may be necessary for that purpose and from time to time deduct the amount so paid by the corporation from any money due or which may become due to the Contractor or recover the same as a debt due from the Contractor.
- 35.13.0- All insurance policies taken by the contractor or his sub-contractor must be in the joint names of contractor, his sub-contractor and the corporation and same shall be pledged with the Corporation.
- 35.14.0- No payment shall be paid to the contractor unless above said insurance coverage policies are submitted by contractor and accepted by Engineer-in-Charge.
- 36.0.0 FACILITIES TO OTHER CONTRACTORS:**
- 36.1.0 The contractor shall, in accordance with the requirement of the Engineer-in-Charge afford all reasonable facilities to other contractors engaged on separate contracts in; connection with the works and for departmental labour of any other properly authorized authority or statutory body which may be employed at the Site on execution of any works not included in the Contract or ancillary to the works. In case of any conflict of interest, decision of Engineer-in-Charge shall be final and binding on the parties.
- 37.0.0- NOTICES TO LOCAL BODIES:**
- 37.1.0- Contractor shall comply with and give all notices required under any Governmental authority, instrument, rule or order made under any Act of Parliament, State laws or any regulation or bye-laws of any local authority relating to the Works. He shall, before making any variation from the contract drawings necessitated by such compliance, give to the Engineer-in-Charges a written notice giving reasons for the proposed variation and obtain the Engineer in charge's instructions thereon.
- 37.2.0- The Contractor shall pay and indemnify the corporation against any liability in respect of any fees or charges payable under any Act of parliament, State laws or any Government instrument rule or order and any regulations or bye laws of any local authority in respect of the works.
- 38.0.0- TRANSFER OF THE CONTRACT & SUB-CONTRACT:**
- 38.1.0- This contract has been made in reliance upon the qualifications and responsibility of the contractor and any advance payments made hereunder are intended to assist him in part in financing of the performance of the work. Therefore, the Contractor shall not assign or transfer this contract or any part thereof or any money due under this contract without the written consent of Accepting Authority. However, the Contractor may sublet portions of the work to be performed hereunder to such persons as the Accepting Authority may expressly approve in writing for which purpose the Contractor shall inform the Engineer-in-Charge in writing the names of all sub-contractors proposed for the work together with the extent and character of the work to be done by each sub-Contractor on this work.
- 38.2.0- If for any reason, at any time during the progress of work the Engineer-in-charge determines that any sub-Contractor is incompetent or undesirable, he will notify the Contractor accordingly and immediate steps shall be taken by the Contractor for cancellation of such sub-contract. Subletting by the Contractor shall be subject to the same regulations as the contract but nothing contained in this contract shall create any contractual relation between any sub-contractor and the Corporation. Allowing any sub-contract and approval of any sub-Contractor shall not under any circumstances operate to relieve the contractor, his sureties, of any of his or their obligations under the contract neither shall any sub-contract or approval of any sub-Contractor create or be deemed to create any rights in favour of such Sub- Contractors against the Corporation. All sub-Contractors shall be understood to be based upon the requisite performance by the sub-



Contractor in accordance with this contract and should any sub-Contractor fail to perform the work to the satisfaction of the Engineer-in-Charge, the latter shall have the absolute right to rescind his approval at once and to require the performance of such works by the contractor himself entirely or in part through other approved sub-Contractor.

39.0.0- INSTRUCTIONS AND NOTICES:

39.1.0- Subject to as otherwise provided in this contract, all notices to be given on behalf of the Corporation and all other actions to be taken on its behalf may be given or taken by the Engineer-in-Charge or any officer for the time being entrusted with the functions, duties and powers of the Engineer-in-Charge.

39.2.0- All instructions, notices and communications, etc., under the contract shall be given in writing and if sent by registered post to the last known place of abode or business of the Contractor shall be deemed to have been served on the date when in the ordinary course of post these would have been delivered to him.

39.3.0- The Contractor or his agent shall be in attendance at the site (s) during all working hours and shall superintend the execution of the works with such additional assistance in each trade as the Engineer-in-Charge may consider necessary. Order given to the contractor's Agent shall be considered to have the same force as if they had been given to the contractor himself.

39.4.0- The Engineer-in-Charge shall communicate or confirm the instructions to the Contractor in respect of the execution of works in a Works Site Order Book maintained in the office of the Engineer-in-Charge and the Contractor or his authorized representative shall confirm receipt of such instructions by signing the relevant entries in this Book. If required by the Contractor he shall be furnished a certified true copy of such instruction(s).

40.0.0- FORECLOSURE OF CONTRACT IN FULL OR IN PART DUE TO ABANDONMENT OR REDUCTION IN SCOPE OF WORK.

40.1.0- If at any time after acceptance of the tender, the Corporation shall decide to abandon or reduce the scope of the work for any reason whatsoever and hence not require the whole or any part of the Works to be carried out, the Engineer-in-Charge shall give notice in writing to that effect to the Contractor and the Contractor shall have no claim to any payment of compensation or otherwise whatsoever on account of any profit or advantage which he might have derived from the execution of the works in full but which he did not derive in consequence of the foreclosure of whole or part of the works.

40.2.0- The Contractor shall be paid at Contract rates full amount of work executed at site and any other amount as admissible under contract.

41.0- TERMINATION OF CONTRACT:

41.1.0- If the Contractor is an individual or a proprietary concern and the individual or proprietor dies and if the contractor is a partnership concern and one of the partners dies then unless the Accepting Authority is satisfied that the legal representative (s) of the individual Contractor or of the proprietor of the proprietary concern and in the case of partnership the surviving partners, are capable of carrying out and completing the contract, the Accepting Authority shall be entitled to cancel the Contract as to its incompleting part without the Corporation being in any way liable to payment of any compensation to the estate of the deceased Contractor and/or to the surviving partners of the Contractor's firm on account of the cancellation of the Contract. The decision of the Accepting Authority that the legal representatives of the deceased Contractor or the surviving partners of the Contractor's firm can not carry out and complete the Contract shall be final and binding on the parties. In the event of such termination the Corporation shall not hold the estate of the deceased Contractor and/ or surviving partners of the Contractor's firm liable for damages for not completing the Contract.

42.0.0- Cancellation of Contract in full or in Part:

42.1.0- If the Contractor:

- (a) At any time make default in proceeding with the works with due diligence and continues to do so after a notice in writing of 7 days from Owner, or
- (b) commits default in complying with any of the terms and conditions of the Contract and does not remedy it or take effective steps to remedy it within 7 days after a notice in writing is given to him in that behalf by the Owner, or



- (c) fails to complete the works or items of the work with individual dates of completion, on or before the date(s) of completion, and does not complete them within the period specified in a notice given in writing in that behalf by the Owner, or
- (d) shall offer, or given or agree to give to any person in Corporation's service or to any other person on his behalf any gift or consideration of any kind as an inducement or reward for doing or forbearing to do or having done or forborne to do any act in relation to the obtaining or execution of this or any other Contract for the Corporation, or
- (e) shall enter into any contract with the Corporation in connection with which commission has been paid or agreed to be paid by him or to his knowledge, unless the particulars of any such commission and terms of payment thereof have previously disclosed in writing to the Accepting Authority/Engineer-in-Charge, or
- (f) shall obtain a Contract from the Corporation as a result of ring tendering or other non-bonafide methods of competitive tendering, or
- (g) Being an individual, or if a firm, any partner thereof, shall at any time be adjudged insolvent or have a receiving order or order for administration of his Estate made against him or shall take any proceedings for liquidation or composition (other than voluntary liquidation for the purpose of amalgamation or reconstructions) under any insolvency Act for time being in force for the sequestration of his estate or if trust deed be executed by him for benefit of his creditors, or
- (h) being a company, shall pass a resolution or the court shall make an order for the liquidation of its affairs, or a receiver or manager on behalf of the debenture holders shall be appointed or circumstances shall arise which entitle the Court or debenture holders to appoint a receiver or manager, or
- (i) shall suffer an execution being levied on his goods and allow it to be continued for a period of 21 days , or
- (j) assigns, transfers, sublets (engagement of labour on piece work basis or of labour with the materials not being incorporated in the work, shall not be deemed to be subletting) or attempts to assign, transfer or sublet the entire works or any portion thereof without the prior written approval of the Accepting Authority.

The Accepting Authority may without prejudice to any other right to remedy which shall have accrued or shall accrue thereafter to the Corporation by written notice cancel the contract as a whole or only such items of the work in default from the Contract.

42.2.0- The Accepting Authority shall on such cancellation have powers to:

- (a) Take possession of the site and any materials, constructional plant, implements, stores etc. thereon, and or
- (b) Carry out the incomplete work/ part work/ part incomplete work of any item(s) by any means at the risk and cost of the Contractor.

42.3.0- On the cancellation of the contract in full or in part the Accepting Authority shall determine what amount, if any, is recoverable from the Contractor for completion of works or part of the works, or in case the Works or part of Works is not completed the loss or damage suffered by the Corporation in determining the amount, credit shall be given to the contractor for the value of the work executed by him up to the time of cancellation, the value of Contractors material taken over and incorporated in the work, and use tools & tackles and machinery belonging to the Contractor. The plant & machinery and materials etc. deployed at site by the Contractor for the works shall be in the custody of Engineer-in-Charge or his representative.

42.4.0-The certificate of the Engineer-in-Charge as to the value of works done shall be final and conclusive against the contractor provided always that action under this clause shall only be taken after giving notice in writing to the contractor. Provided also that if the expenses incurred by the corporation are less than the amount payable to the contractor at his agreement rates, the difference shall not be payable to the contractor.

Any excess expenditure incurred or to be incurred by the Corporation in completing the works or part of the works or the excess loss or damages suffered or may be suffered by the Corporation as aforesaid after allowing such credit shall be recovered from any money due to Contractor on any account, and if such money are not sufficient, the Contractor shall be called upon in writing to pay the same within 30 days.



- 42.5.0- If the Contractor shall fail to pay the required sum within the aforesaid period of 30 days, the Engineer-in-Charge shall have the right to sell any or all of the Contractor's unused materials, constructional plant, implements, temporary building, invoke Bank guarantees etc. and apply the proceeds of sale thereof towards satisfaction of any sum due from the contractor under the Contract and if thereafter there be any balance outstanding from the Contractor it shall be recovered in accordance with the provisions of the Contract.
- 42.6.0- Any sum in excess of the amounts due to the Corporation and unsold materials, constructional plant, etc. shall be returned to the contractor, provided always that its cost or anticipated cost of completion by the corporation of the Works or part or the works is less than the amount which the contractor would have been paid had he completed the works or part of works, such benefit shall not accrue to the Contractor.
- 43.0.0-LIABILITY FOR DAMAGE DEFECTS OR IMPERFECTIONS AND RECTIFICATION THEREOF:**
- 43.1.0- If the Contractor or his workman or employees shall injure or destroy any part of the building in which they may be working or any building, road, fence etc. Contiguous to the premises on which the work or any part of its is being executed or if any damage shall happen to the work while in progress, the Contractor shall upon receipt of a notice in writing in that behalf make the same good at his own expense. If it shall appear to the Engineer-in-Charge or his representative at any time during construction or re-construction or prior to the expiration of the Defects Liability Period that any work has been executed with unsound, imperfect or unskilled workmanship or that any materials or articles provided by the Contractor for execution of the work are unsound or of a quality inferior to that contracted for, or otherwise not in accordance with the contract, or that any defect, shrinkage or other faults have appeared in the work arising out of defective or improper materials or workmanship, the Contractor shall upon receipt of a notice in writing in that behalf from the Engineer-in-Charge, forthwith, rectify or remove and reconstruct the work so specified in whole or in part, as the case may require or as the case may be and/or, remove the materials or articles so specified and provide other proper and suitable materials or articles at his own expense, notwithstanding that the same may have been inadvertently passed, certified and paid for and in the event of his failing to do so within the period to be specified by the Engineer-in-Charge in his notice aforesaid, the Engineer-in-Charge may rectify or remove and re-execute the work and/or remove and replace with others, the materials or articles complained of, as the case may be, by other means at the risk and expense of the Contractor.
- 43.2.0- In case of repairs and maintenance works, splashes and droppings from white washing, painting etc. shall be removed and surfaces cleaned simultaneously with completion of these items of work in individual rooms, quarters or premises, etc. where the work to be done, without waiting for completion of all other items of work in the contract. In case the Contractor fails to comply with the requirements of this condition, the Engineer-in-Charge shall have the right to get the work done by other means at the cost of the Contractor. Before taking such action, however the Engineer-in-Charge shall give three days notice in writing to the Contractor.
- 44.0.0- URGENT WORKS:**
- 44.1.0- If any Urgent Work (in respect whereof the decision of the Engineer-in-Charge shall be final and binding) becomes necessary and the Contractor is unable or unwilling at once to carry it out, the Engineer-in-Charge may by his own or other work people, carry it out as he may consider necessary. If the Urgent work shall be such as the contractor is liable under the Contract to carry out at his expenses, all expenses incurred on it by the Corporation shall be recoverable from the Contractor and be adjusted or set off against any sum payable to him.
- 45.0.0- CHANGES IN CONSTITUTION:**
- 45.1.0- Where Contractor is a partnership firm, JV, Consortium prior approval in writing of the Accepting Authority shall be obtained before any change is made in the constitution of the firm/JV/ Consortium partners. Where the contractor is an individual or a Hindu Undivided Family business concern or a company such approval, as aforesaid, shall likewise be obtained before the contractor enters into any partnership firm or forms a JV or Consortium, which would have the right to carry out the work hereby under taken by the Contractor. If prior approval as aforesaid is not obtained, the contract shall be deemed to have been assigned in contravention of



clause 42.0.0 hereof and the same action may be taken and the same consequences shall ensure as provided for in the said clause

46.0.0- TRAINING OF APPRENTICES:

46.1.0. The Contractor shall during the currency of the contract when called upon by the Engineer-in-Charge engage and also ensure engagement by subcontractor and other employed by the Contractor in connection with the works, such number of Apprentices in the various categories, and for such period as may be required by the Engineer-in-Charge. The Contractor shall train them as required under the Apprentices Act, 1961 and shall be responsible for all obligations of the employer under the Act including the liability to make payment to apprentices as required under the Act.

47.0.0- SUPPLY OF WATER FOR CONSTRUCTION PURPOSES:

47.1.0. Normally the water for construction purposes shall be provided at one point near the working site free of cost if available with the Corporation. However, if it is not provided, contractor has to make his own arrangement as per site requirements without any extra cost to the Corporation so as to complete the entire works within Time Schedule.

47.2.0. The Corporation do not guarantee the maintenance of uninterrupted supply of water and in case of any interruption of such supply of water for any reason or for any duration, the contractor shall be responsible for making at his own cost, alternative arrangements for water. The Engineer-in-Charge also reserves the right to limit the quantity of water to be allowed to be drawn by the Contractor.

47.3.0. No claim for damage will be entertained by the Corporation on account of interruption of water supply for any reason or for any duration or limitation of quantity of water as aforesaid or on account of the water so supplied being not fit for construction purposes or on any other account in connection with such water supply.

47.4.0. It will be the responsibility of the contractor to satisfy himself that the water drawn by him is fit for construction and to adequately treat such water at his own cost when it is not found fit for the said purposes.

48.0.0- ARRANGEMENT FOR DRINKING WATER:

The Contractor has to make his own arrangement for drinking water at his works site and for his labour /staff colony at his own cost.

49.0.0- LAND FOR CONTRACTOR'S OFFICE, STORE, WORKSHOP ETC.

49.1.0- Tenderer shall indicate their requirement of land for their site office (s), labour/staff colonies and store etc. in their tender proposal. The same may be provided free of charge after examination, if available with the Corporation. However, leveling, dressing, approaches etc. are to be done by the Contractor at his own cost after the approval from Engineer-in-Charge. If the land is not available with the Corporation for the said purposes, the contractor has to arrange the land for the said purposes at its own cost.

49.2.0- On completion of works, within three months, the contractor shall handover the land duly cleaned to the Engineer-in-charge. Until and unless the Contractor has handed over the vacant possession of land allotted to him for the above purpose, the payment of his final bill shall not be made. The contractor shall be made liable to pay for the use and occupation at the rates to be determined by the Engineer-in-Charge if the contractor overstays in the land after expiry of three months of completion of works.

50.0.0- POWER SUPPLY:

50.1.0.- Corporation will provide electricity to be consumed at the job site for execution of works (excluding labour/ staff colony) at one point of the distribution system as per requirement if not specifically excluded. The electricity furnished will be 440 volts, 3 phase, 50 cycles and 230 volts, 1 Phase, 50 cycle. Contractor shall provide and install necessary transformers, switch gear, wiring, fixtures, bulbs, earthing protection system and other temporary equipment for further distribution and utilization of energy of power, lighting in accordance with the provision of Indian Electricity Act/ rules or any other law in force and to the satisfaction of the Engineer-in-charge and shall remove same on completion of the work. Electricity so consumed in the works shall be free of cost or charged on rates as applicable (**as specified in Special Conditions of Contract**). The supply may be withdrawn if the power is used for purpose other than for the works under the contract and the contractor shall not be entitled to any claim whatsoever on account of any such action taken by the Engineer-in-charge.



- 50.2.0- The contractor shall indicate his requirements of power for construction purpose in his tender.
- 50.3.0- The contractor has to make his own arrangements at his cost for Stand by Power Supply through Generating sets of suitable capacity to cater to the requirements of essential works. The details of such arrangement are to be furnished to Engineer-in-charge.
- 50.4.0- Contractor has to make his own arrangement for the power required for their labour/staff colony at their own cost.
- 50.5.0- The contractor shall not be entitled for any claim of any nature due to non availability or interrupted power supply of any duration or for any reason under any circumstances.
- 51.0.0- VALUATION AND PAYMENT**
- 51.1.0- Records and Measurement**
- 51.1.1- The Engineer-in-charge shall except as otherwise stated ascertain and determine by measurement the value of work done in accordance with the contract.
- 51.1.2- All items having a financial value shall be entered in measurement book, level book, etc. prescribed by the Corporation so that complete records are obtained of all the work performed under the contract.
- 51.1.3- Measurement shall be taken jointly by the Engineer-in-charge or his authorized representative and by the Contractor or his authorized representative.
- 51.1.4- Before taking measurement of any work, the Engineer-in-charge or the person deputed by him for the purpose shall give a reasonable notice to the contractor. If the Contractor fails to attend or send an authorized representative for measurement after such a notice or fails to countersign or record the objection within a week from the date of measurement, then in any such event measurement taken by the Engineer-in-charge or by the person deputed by him shall be taken to be correct measurement of the work.
- 51.1.5- The contractor shall, without extra charge, provide assistance with every appliance labour and other things.
- 51.1.6- Measurement shall be signed with date by both parties each day on the site on completion of measurement. If the contractor object to any of the measurement recorded on behalf of the Corporation a note to that effect shall be made in the measurement book against the item objected to and such note shall be signed and dated by both parties engaged in taking the measurement. The contractor should inform the same in writing to the Engineer-in-charge with intimation to accepting authority within 7 days. The decision of the Accepting Authority on any such dispute or difference or interpretation shall be final and binding on both the parties and shall be beyond the scope of the settlement of dispute by Arbitration.
- 51.2.0- METHODS OF MEASUREMENT:**
Except where any general or detailed description of the work in quantities expressly shows to the contrary, Schedule of Quantities shall be deemed to have been prepared and measurement shall be taken in accordance with the procedure set forth in the Schedule of rates/ Specification notwithstanding any provision in the relevant standard method of measurement of any general or local custom. In the case of item which are not covered by the Schedule of Rates/Specification, measurement shall be taken in accordance with the relevant standard method of measurement issued by the Indian Standard Institution/or CPWD specifications.
- 51.3.0- PAYMENT ON ACCOUNT**
- 51.3.1- Interim bill shall be submitted by the contractor on monthly basis on or before the date fixed by the Engineer-in-Charge for the work executed. The Engineer-in-Charge shall then arrange to have the bill verified by taking or causing to be taken where necessary, the requisite measurement of the work.
- a) Payment on account for amount admissible as per clause 51.3.1 shall be made by the corporation on the Engineer-in-Charge certifying the sum to which the contractor is considered entitled by way of and submitted the following :
- (i) Acceptance of letter of Award.
 - (ii) Signed contract Agreement
 - (iii) Insurance policy submitted.
 - (iv) Initial part of security deposited/or Bank Guarantee amended as per security deposit format.



- (v) Indemnity bond for free issue material, if any, submitted and verification of all works executed, after deducting there from the amounts already paid, security deposit and such other amount as may be deductible or recoverable in the contract.
- b) 75 % of actual cost or 75% of the material cost in the particular item rates appearing in letter of award whichever is lower for any material which in the opinion of Engineer-in-Charge are reasonable and required in accordance with the contract and have been brought to site for incorporation in the work within a maximum period of six month and are safe guarded against loss due to any cause what so ever to the satisfaction of Engineer-in-Charge and certification of QA personnel for quality surveillance.
- 51.3.2- The advance payment under (b) above shall be adjusted as and when materials are utilized in the works, or within a maximum period of 6 months.
- 51.3.3- Payment of contractor's bill shall be made by the corporation within 15 days from the date of submission of the bill duly certified by Engineer-in-Charge & certification of Quality surveillance by QA representatives.
- 51.3.4- Any interim certificate given relating to work done or materials delivered, may be modified or corrected by any subsequent interim certificate or by the final certificate. No certificate of the Engineer-in-Charge supporting any interim payment shall itself be conclusive evidence that any work or materials to which it relates is/are in accordance with the contract.
- 51.3.5- Pending consideration of extension of date of completion interim payments shall continue to be made as herein provided, after with holding the amount towards Liquidated Damages.
- 51.3.6 All Payments of contractor's bill shall be made by the corporation only through electronic mode or by transferring payment to the contractor's account provided by the contractor directly (as per **Annexure-A**).
- 52.0.0- **PAYMENT OF FINAL BILLS:**
- 52.1.0- The final bill shall be submitted by the Contractor within three months of physical completion of the work along with the following:-
- (i) Reconciliation sheet of free issued material
 - (ii) All statutory payment certificate like royalties etc.
 - (iii) Work completion certificate
 - (iv) Submission of as built drawings
 - (v) No claim certificate
 - (vi) Extension of bank guarantee.
 - (vii) Rectification of defects, if any.
- No further claims shall be made by the contractor after submission of the final bill and these shall be deemed to have been waived and extinguished.
- 52.2.0- Payment towards extra items, substituted items and deviated items etc shall be made only after issue of Amendment to letter of Award indicating rates and quantity and their acceptance by the contractor.
- 53.0.0- **CONTRACT PRICE ADJUSTMENT:**
- 53.1.0 The rates quoted by the bidder shall be the base price, which will be subjected to PRICE ADJUSTMENT unless otherwise provided in the **Special Conditions of Contract** in accordance with the conditions and formula prescribed herein and further subject to satisfying the requirements specified in this clause only.
- 53.2.0 The "Contract Price" as awarded shall be the base price, unless other wise specified. A certain fixed percentage of the base price shall not be subject to any price adjustment. The balance percentage to be specified shall be of identified components towards Labour, Material (S) and H.S. Diesel Oil (P.O.L.) and shall be subject to price adjustment. The fixed components and the identified components shall vary from contract to contract depending upon the scope of work (s) and shall be furnished in the special conditions to contract, which will be attached to the tender documents.
- 53.3.0 The actual amount of price adjustment shall be determined satisfying the conditions specified here in and shall not exceed the maximum limit as specified in sub-clause 53.6 herein below.
- 53.4.0 The price adjustment formula for the various components of the contract price, shall be construed as stipulated here in after. The formula designed for governing and calculating the price adjustment to the contract price shall be as follows.



$$ACV1 = CV \left[F + \frac{I.L_i}{L_o} + \frac{m.M_i}{M_o} + \frac{d.D_i}{D_o} \right]$$

Where :

ACV1= adjusted contract price i.e. value of work done after application of price adjustment from.

CV= base contract price, subject to price adjustment i.e., the value of the work done in the given period for which the Price Adjustment is to be calculated.

F= Fixed component portion of contract which will not be subjected to any adjustment under this formula or otherwise (and will be quantified from contract to contract in the special conditions of contract).

I= Labour component of the contract price which will be subjected to adjustment: (to be quantified from contract to contract in the special conditions of contract).

m = Material component (excluding owner issue materials) of the contract price which will be subject to adjustment; (and will be quantified from contract to contract, in the special conditions of contract).

d = High Speed Diesel/P.O.L. component of the contract price which will be subject to adjustment; (and will be quantified from contract to contract, in the special conditions of contract). The variation in this component will be available to contract (s) as defined in 53.6 as the case may be.

L= Labour Index, which shall be “Index Number” of “Consumer Price Index” for industrial workers: (All India) (General) (Base 2001=100 or as specified in Special Conditions of Contract) “as published by Labour Bureau Shimla in their monthly bulletin entitled, “ India Labour Journal”

M = Material Index, which will be the “Index Number” of “Index Number of wholesale Price” under group “ All commodities (Base 2004-05=100 or as specified in Special Conditions of Contract)“ as published by the Ministry of Industry in their Monthly bulletin entitled “Index Number of wholesale prices .”

D = High Speed Diesel Price per Liter; which will be the price of High Speed Diesel Oil at the Indian Oil Corpn. Retail out let nearest to the project (Selling price inclusive of taxes and duties, if any, per liter of High Speed Diesel Oil)

SUBSCRIPT

“o” = refers to the values of the above mentioned labour/ material indices or diesel price as on 30 days prior to the last date of submission of price bid.

“i” = refers to the values of corresponding labour/ material indices or diesel price as applicable for the month prior to the month in which the work is executed for which adjustment is applicable.

53.5.0 The value of “F” as specified in Bid Documents/ special conditions of the contract will remain unchanged and fixed and shall not be disputed.

53.6.0 The total price adjustment (s) in any contract price of any contract shall not exceed the maximum limit (s) specified here below:

(i) For contract (s) where completion period as stipulated is less than and upto 12 months, the prices shall remain ‘FIRM’ and will not be subject to escalation on any account under any circumstances.

(ii) for contract (s) where completion period as stipulated is more than 12 months but not more than 24 months 10% (Ten percent) of the contract price as awarded.

(iii) For contract (s) where completion period as stipulated is more than 24 months but not more than 36 months 15% (Fifteen percent) of the contract price as awarded.

(iv) For contract (s) where completion period as stipulated is more than 36 Months 20% (Twenty percent) of the contract price as awarded.

53.7.0 Price Adjustment (s) shall be calculated for the quantum of works executed for the month or the period of the bill as per agreed work schedule for the purpose of payment/ recovery of price variation provisions, the contractor would be eligible for such claims or shall be liable for refund on the quantum of work scheduled to have been executed in the month or period as per the agreed work schedule or the actual quantum of work done provided always that such quantum of work done is more than or equal to the scheduled quantum of work as per the agreed work schedule. In other words the contractors shall not be eligible for these claims for payment under



- these provisions if the work has been delayed beyond the scheduled date (s) for reason attributable to contractor. However, the contractor would be eligible for claim or liable for refund for price adjustment (s) for quantities of work executed beyond the scheduled dates based on the value of indices as applicable to the scheduled dates of execution, for such delayed work provided that if the indices during the delayed period are lower than the indices during scheduled dates of execution, then lower indices shall be applicable.
- 53.8.0 Additional, altered or substituted items of work, derived from the agreed schedule of rates (attached in Award Letter) will also attract price adjustment as per this clause. No Price adjustment is payable for the rate/amount of the additional, altered or substituted items of work when derived from or based on markets rates. No price adjustment for the cost of Owner issue material (viz, steel & cement or any other item (s) issued from owners stores), hire charges of equipment taken on hire from corporation and electrical energy etc supplied at fixed price shall be applicable. The same shall be deducted from the value of work done while calculating the price adjustment.
- 53.9.0. Every month after the award of contract, the contractors shall submit to the Engineer-in-charge a written notice of the changes, if any, that have occurred in the specified indices of material (s) and labour or that of Diesel Price, during the previous reporting period containing effective date of such change, the amount of change for the claim of the amount of contract price adjustment with authenticated documentary evidence of the relevant published indices/diesel price to substantiate the price adjustment.
- 53.10.0 Provided further that such payment/refund shall not be operative and payable after the schedule expiry of the contract period or authorized extended contract period or extended date of completion of works or items of works in question.
- 53.11.0 In case, the work, or items of works, or group of items of work, are delayed beyond the schedule date for the work, for reasons attributable to the contractor, the price adjustment provisions shall not be applicable for the period of time between the scheduled date and the actual date, but for as provided in sub-clause 53.7.0
- 53.12.0 For this purpose, the schedule date of works shall be as indentified in line with provisions of clauses entitled "Time and extension for Delay" and/or "the bar chart" (which will be discussed and finalized before award of work) where in the separate period of completion has been specified / agreed to, for items , or groups of items, or works.
- 53.13.0 **Total Adjusted Contract Price:**
The total adjusted contract price shall be \sum (Sigma) ACV1 + other elements of price, if any.
- 53.14.0 Except as provided herein, no other expenditure incurred by the contractor, due to levy of additional/ increase in taxes, duties, octroi, royalty, insurance premium (s) benefits to workers/ labours or any other clause (s) /items(s) due to any reason whatsoever, shall be payable to the contractor.
- 54.0.0 **OVERPAYMENT AND UNDERPAYMENTS:**
- 54.1.0- Wherever any claim for the payment of a money or sum of money to the Corporation arises out of or Under this Contract against the Contractor the same may be deducted by the Corporation from any sum then due or which at any time thereafter may become due to the Contractor under this contract and failing that under any other contract with the Corporation or from any other sum due to the Contractor from the Corporation which may be available with the Corporation or from his security deposit/or he shall pay the claim on demand.
- 54.2.0- The Corporation reserve the right to carry out post payment audit and technical examination of the final bill including all supporting vouchers, abstracts, etc. the corporation further reserve the right to recover any overpayment when detected notwithstanding the fact that amount of final bill may be included by one of the parties as an items of dispute before an arbitrator appointed under condition 55 of this contract and notwithstanding the fact that the amount of the final bill figures in the arbitration award or that the amount under the final bill stands already paid to the contractor.
- 54.3.0- If as a result of such audit and technical Examination any overpayment is discovered in respect of any work done by the Contractor or alleged to have been done by him under the contract, it shall be recovered by the Corporation from the Contractor by any or all of the methods prescribed above. If any underpayment is discovered, the amount shall be duly paid to the Contractor by the Corporation.



54.4.0-Provided that the aforesaid right of the Corporation to adjust overpayments against amount due to the Contractor under other contract with corporation shall not extend beyond the period of 3 years from the date of Payment of the final bill or in case the final bill is a MINUS bill from the date the amount payable by the Contractor under the MINUS final bill is communicated to the contractor's.

54.5.0- Any sum of money due and payable to the contractor (including the security deposit returnable to him) under the contract may be withheld or retained by way of lien by the Engineer-in-Charge or corporation against any claim of the corporation or such other person or persons in respect of payment of a sum of money arising out of or under any other contract made by the Engineer-in-Charge or Corporation or with such other person or persons. The sum of money withheld or retained under this clause by the Engineer-in-Charge or Corporation or will be kept withheld or retained as such by the Engineer-in-Charge or corporation till his dues arising-out-of in the same contract or any other contract is either mutually settled or determined by the arbitrator, if the contract is governed by the arbitration clause by the competent court hereinafter provided, as the case may be, and the contractor shall have no claim for interest or damages whatever on this account or any other ground in respect of any sum of money withheld or retained under this clause.

54.6.0 – NO CLAIM FOR DELAYED PAYMENT DUE TO DISPUTE ETC.

No claim for interest or damage will be entertained or be payable by the Corporation in respect of any amount or balances which may be lying with the Corporation owing to any dispute, difference or misunderstanding between the parties or in respect of any delay or omission on the part of the Engineer-in-Charge in making intermediate or final payments or in any other respect whatsoever.

54.7.0 – INTEREST ON MONEY DUE TO THE CONTRACTOR

No omission on the part of the Engineer-in-Charge to pay the amount due upon measurement or otherwise shall vitiate or make void the contract, nor shall the contractor be entitled to interest upon any guarantee or payments in arrears nor upon any balance which may on the final settlement of his account, be due to him.

55.0.0- ARBITRATION

Except where otherwise provided in the contract all questions and disputes relating to the meaning of the specifications designs, drawings and instructions hereinbefore mentioned and as to the quality of workmanship or materials used on the work or as to any other question, claim, right matter or thing whatsoever, in any way arising out of or relating to the contract, designs, drawings, specifications orders or these conditions or otherwise concerning the works, or the execution or failure to execute the same whether arising during the progress of the work or after the completion or abandonment thereof shall be referred to the sole arbitration of a person appointed by the chairman and Managing Director or if there is no Chairman & Managing Director of the Corporation, functional director administratively in charge of the work. It will be no objection to any such appointment that the arbitrator so appointed is serving officer of the corporation. The arbitrator to whom the matter is originally referred being transferred or vacating his office of being unable to act for any reason, Chairman & Managing Director of the Corporation or functional Director as aforesaid at the time of such transfer/ vacation of office or inability to act shall appoint another person to act as arbitrator in accordance with the terms of contract. Such person shall be entitled to proceed with the reference from the stage at which it was left by his predecessor. It is also a term of this contract that no person other than a person appointed by the Chairman & Managing Director or Functional Director, as aforesaid should act as arbitrator. If for any reason, that is not possible, the matter is not to be referred to arbitration at all. In all cases where the amount of the claim in dispute is Rs. 50,000 (Rupees Fifty Thousand) and above, the arbitrator shall give reason for the award. Subject to as aforesaid, the provisions of the Arbitration act, 1996, or any statutory modification or reenactment thereof and the rules made there under and for the time being in force shall apply to the arbitration proceedings under this clause. It is also a term of the contract that the party invoking arbitration shall specify the dispute or disputes to be referred to arbitration under this clause together with the amount or amounts claimed in respect of each such dispute.

It is also a term of the contract that if the contractor does not make any demand for arbitration in respect of any claim(s) in writing within 90 days of receiving the intimation from the Corporation



that the bill is ready for payment, it shall be deemed that the contractor has accepted the bill unequivocally and the contractor shall be barred from seeking arbitration thereafter and the Corporation shall stand discharged and released of all liabilities under the contract in respect of claims.

In the case of contract with the public sector undertaking, instead of above provision relating to the settlement of dispute & differences in the contract, the following provision shall apply. Except otherwise provided, in the event of any dispute or difference relating to interpretation and application of the provisions of the contract such disputes or differences shall be referred by either party to the arbitration of one of the Arbitrators in the Department of Public Enterprises to be nominated by the Secretary to the Government of India in charge of the Bureau of Public Enterprises. The Arbitration Act 1996 shall not be applicable to the arbitration under this clause. The award of the Arbitration shall be binding upon the parties to the dispute, provided however any party aggrieved by such award may make a further reference for setting aside or revision of the award to the Law Secretary, Department of Legal Affairs, Ministry of Law & Justice, Government of India. Upon such reference, the dispute shall be decided by the law Secretary or the special Secretary/ additional Secretary when so authorized by the Law Secretary, whose decision shall bind the parties finally and conclusively.

The parties to the dispute will share equally the cost of arbitration as intimated by the Arbitrator. The venue of arbitration shall be Delhi or any other place decided by the arbitrator in agreement with the parties.

During the Arbitration proceedings Contractor shall continue the work.

56.0.0- FORCE MAJEURE

If, at any time, during the continuance of this contract, the performance in whole or in part by either party of any obligation under this contract shall be prevented or delayed by reason of any war, hostility, acts of the public enemy, civil commotion, sabotage, fires, floods, explosions, quarantine, restriction, strikes, lock-outs or acts of God (hereinafter referred to as "events"), provided by notice of happening of any such eventually is given by either party to the other within 7 days from the dates of occurrence thereof, neither party shall by reason of such event be entitled to terminate this contract nor shall either party have any claim for damages against the other in respect of such nonperformance, or delay in performance and work under the contract shall be resumed as soon as practicable after such event has come to end or ceased to exist, and the decision of Engineer-in-Charge, as to whether the work has been resumed or not, shall be final and conclusive and the relevant Provision of this agreement governing settlement of dispute and difference through Arbitration will not apply. The contractor shall within 7 days of such occurrence apply to the corporation together with adequate evidence for obtaining such extension of time as may be warranted by the circumstances. After a careful examination of the circumstances the corporation may grant such extension of time as necessary without insisting on liquidated damages. "Neither party to the contract shall be liable to the other in respect of any loss or damage which may occur or arise out of "Force Majeure" to the work or any part thereof or to any material or article or to any person or anything whatsoever of either party provided such a loss or damage could not have been foreseen or avoided by a prudent person and that either party shall bear losses or damages in respect of their respective workman and materials. And such liability of either party shall include claims/compensation of the third party/parties.

57.0.0 DISCRETION OF CORPORATION:

- (a) If at the discretion of Corporation or due to any reason (except a default of the contractor) the work under the contract is suspended or is to be suspended for more than fifteen days by way of a suspension order, then contractor is liable to get idle labour charges for his permanent labour deployed at works. The idle labour charges shall be mutually discussed and agreed to with Engineer-in-Charge with a ceiling of Rs. 50, 000/- per month. The limit can however, be increased by accepting authority. No Idle labour charges shall be payable for the first 15 days of suspension of work.
- (b) If work is suspended because of any fault of the Contractor no idle labour charges shall be payable by the corporation to the contractor.

57.1.0 No idle labour charges shall be paid to the contractor in the following cases:-

- (a) Non-availability of front.



- (b) Non-availability of Power Supply / Materials/ Water/ Drawing / Construction Equipments etc.
- (c) Disturbance and agitation by local people, if any.
- (d) Non-payment of on account bills.
- (e) Bad weather / Climatic conditions or any eventuality not covered under force majeure.
- (f) If at any point of time during currency of contract sufficient resources has not been mobilized by contractor to maintain the progress of work.
- (g) During force majeure condition.

58.0.0- PROGRESS REPORT:

The contractor has to furnish "Progress Report" indicating details of labour and equipment deployed and the quantum of work done, and other relevant information during the fortnight to the Engineer-in-Charge in the prescribed proforma as he may require to assess and ensure proper progress of work. The progress report is to be submitted on 1st and 16th of every month to the Engineer-in-Charge. One copy of the progress report may be sent to the authority issuing Letter of Award and Planning department.

59.0.0- TIME SCHEDULE:

The work is to be completed in all respects within the specified time schedule (**Refer special condition of contract**). The successful bidder is to furnish the BAR CHART in line with the time schedule within 7 days of award of contract which shall be mutually discussed and agreed to and the same shall form a part of contract Agreement.

60.0.0 LAW GOVERNING THE CONTRACT

The contract shall be governed by the Indian Laws for the time being in force and the court located at Delhi shall have the sole jurisdiction.

61.0.0 Examination by Chief Technical Examiner (CTE), Govt. of India:

The work(s) will be open to examination by CTE (Chief Technical Examiner) or by any other agency of Govt. of India. The Corporation will in no way be responsible if as a result of the above said examination, some discrepancies/ defects are noticed and that it will be the responsibility of the contractor to make good/ rectify all the defects/ discrepancies/ shortcomings and any recovery, if advised on such examination will be effected by the corporation and the contractor shall agree to it without demur or reservation.



Section – V

Special Conditions of Contract



Section –V

Special Condition of Contract

- 1. CONSTRUCTION PLANT AND MACHINERY (CLAUSE 13.0.0 OF GCC)**
The contractor shall arrange at his own expense all tools, plant, equipment (herein after referred to as T&P) required for execution of work.
- 2. MATERIAL TO BE SUPPLIED BY THE CORPORATION (CLAUSE 15.0.0 OF GCC)**
No material shall be supplied by the Corporation. The Contractor at his own expenses, provide/ arrange all materials including cement and steel for bona-fide use in work under the contract.
- 3. LICENSE FEE (CLAUSE 18.0.0 (I) OF GCC)**
Not applicable.
- 4. DEFECT LIABILITY PERIOD (CLAUSE NO. 34.0 OF GCC).**
Defect liability period shall be 12 months from the date of certified completion of the work.
- 5. POWER SUPPLY (CLAUSE NO. 50.0 OF GCC):**
THDCIL shall provide power supply at L.T. level at 3 locations opted by the contractor & Metering and protection shall be installed by the contractor for the same. Electronic calibrated energy meter with its calibration certificate shall be provided by the contractor. Periodic calibration shall be in the scope of contractor. Monthly consumption shall be submitted by the contractor which shall be verified by the EIC and the same shall be charged as per the per KWH (Unit) rate prescribed by UPCL.
The contractor at his own cost shall make his own arrangement for Power supply for his labour and staff.
- 6. CONTRACT PRICE ADJUSTMENT (CLAUSE 53.0.0 OF GCC)**
Not applicable.
- 7. TIME SCHEDULE FOR COMPLETION (CLAUSE 59.0.0 OF GCC)**
The entire work is to be completed within twelve (12) months from the date of start specified in LOA. Tenderer shall submit a work program. This work program shall be clearly indicate major key events as per requirements so as to complete the works within time frame stated above.
A detailed work program shall be discussed with successful tender after award of contract and shall be mutually agreed to such detailed work program/bar chart and shall form a part of the contract agreement and all activities shall be performed and completed as per specification strictly in accordance with such agreed program/Bar chart.
- 8. LOCATION AND COMMUNICATION:**
Vishnugad-Pipalkoti Hydro Electric Project on river Alaknanda is located between Vishnuprayag confluence of river Alaknanda & Dhoulī Ganga in the upstream and Bawala Nandprayag Hydel scheme located on downstream side near village Jaisal in district Chamoli Uttarakhand. Pipalkoti town is located about 225 KM from Rishikesh on NH-58. The work sites are located at Siyasain.
The tenderer is advised to visit the site and assess the site condition and local conditions such as approach roads to the site, water supply, electricity etc. Tenderer shall be deemed to have considered site conditions and to have satisfied himself in all respects before quoting rates.
- 9. The following documents shall form a complete set of tender documents:**
 1. Notice Invited tender.
 2. Information and Instructions to bidders.
 3. General Conditions of Contract for civil works.
 4. Special Conditions of Contract.
 5. Technical Specifications and Tender Drawings, if any.
 6. Schedule of Items/ Bill of Quantities.
- 10. SCOPE OF WORK:**
The scope of work consists “Construction of Rock fall protection barrier at B-Block colony at VPHEP”. All items shall be carried out as per C.P.W.D Specification and all market purchased items shall be as per I.S. specification. The work shall be carried out as per relevant IS code (latest edition) unless otherwise specified in the nomenclature of individual items/ particulars specification.



The work to be performed under this contract consists of providing all labour, supervisors, materials, scaffolding, fuel, construction equipment, tools and plants, supplies transportation, storage, insurance and all incidental items not shown or specified but reasonably implied or necessary for successful completion of the work including contractors and where necessary manufacturer expert supervision and in strict accordance with the drawings and specification.

The entire work has to be executed according to requirements of premises with additions, alternations retrofitting etc. from time to time as required or approved by the Engineer-in-charge. If work is required to be executed as per drawings, it shall be supplied to the contractor progressively during the execution of the contract.

11. TEMPORARY WORK:

All scaffolding, staging and other temporary work required for proper execution of the work shall be provided by the contractor at his own cost and his quoted rates shall be inclusive of providing for all materials, labour and supervision for such work. The layout and details of such temporary work shall have the prior approval of the Engineer-In-Charge.

The contractor shall be responsible for proper strength of temporary work scaffolding, staging etc so constructed /erected. A due consideration shall be given to safety of personnel engaged for construction and erection. All temporary work shall be so constructed as not to interfere with any permanent work or with the work of other agencies. If it is necessary to remove any of the temporary work at any time to facilitate execution of the work of other agencies, such removal and re-erection, if required, shall be carried out by the contractor at the discretion of the Engineer-In-Charge without any delay, and no extra cost on this account.

12. OBSERVATIONS OF LABOUR LAWS:

In additions to the provisions provided in clauses related to labour laws in General Conditions of Contract, the following provisions shall hold good.

The contractor shall be liable to make payments to all his employees and shall comply with labour laws, if the OWNER is held liable as “PRINCIPAL EMPLOYER” to pay contribution etc. under E.S.T, P.F. Act, or any other legislation of Government or of Court decision, in respect of the employee of the contractor, then the amount of the such contribution so paid by the OWNER, shall be recovered from contractor.

13. QUALITY ASSURANCE PROGRAMME:

To ensure that the service under the scope of this contract are in accordance with the specifications, the contractor shall adopt suitable Quality Assurance Program to control such activities at all necessary, check points. Q.A. Program will be submitted by successful tenderer. The same shall be discussed and mutually agreed to and will be followed during execution of work.

14. TEST OF MATERIALS AND WORKMANSHIP:

Test required for all materials as desired by the Engineer-In-Charge shall be at contractor's cost. Quality of workmanship shall be as per tender documents, technical specifications and relevant IS codes and to the satisfaction of Engineer-In-Charge.

15. PAYMENT:

The progressive interim monthly payments shall be released as detailed in GCC subject to Certification by Owner's field Quality Assurance representative that the “work have been performed in accordance with quality control parameters provided in the contract and certificate of Engineer-in-charge that work have been executed as per technical Specifications provided in the contract and contractor's certification that for the entire material brought to site for use in the works are not under dispute with any third party.

16. WATER:

The contractor at his own cost shall make his own arrangement for Drinking Water and Water, for construction purposes.

17. ADVANCE FOR MATERIAL:

No material advance payments shall be made to the contractor.

18. DEPLOYMENT OF MANPOWER:



For full, proper and continuous supervision of the work under the contract, the contractor shall engage and mobilize the necessary contingent of qualified and experienced manpower (including technical staff) at site. The details, of the total staff deployment shall be as per requirements of work.

The technical staff should be available at site, wherever required by Engineer-In-Charge to take instruction.

- 19. SITE TO THE CONTRACTOR FREE FROM ENCUMBRANCE:**
Efforts will be made by the Corporation to handover the site to the contractor free from encumbrance. However, in case of delay in handling over the site to the contractor THDC shall only consider suitable extension of time for the execution of the work. It should be clearly understood that THDC shall not consider any compensation whatsoever viz. towards idleness of contractor's labour, equipment etc.
- 20. INFORMATION TO BE SUBMITTED BY TENDERERS ALONGWITH TENDER:**
The tenderer shall without failure submit all the information as called for in the Technical Specification, GCC, SCC and information in support of pre-qualification requirements as mentioned in N.I.T. This is essential in assessing the Contractor's capacity to execute the proposed works. Tenders containing incomplete information are liable to be rejected.
- 21.** The EMD submitted by bidder shall be forfeited if on verification, any document submitted by the bidder is found to be false and fabricated before or after award of work. If during the progress of work above facts are noticed, the work shall stand terminated and no compensation whatsoever will be payable to the contractor.
- 22.** Issue of tender documents does not automatically mean that bidders are considered. THDC reserves the right to reject any or all the tenders or split the work, enhance or dilute qualifying requirements and to assess the capacity of the bidder in the overall interest of THDC without assigning any reason whatsoever.
- 23.** The contractor will obey all the wild life protection rules of central and state government.
- 24.** The contractor will render all help, required during the currency of field investigations and tests.
- 25.** CPWD specification shall be followed. Where not available, BIS/Engineering practice as directed by the Engineer shall be followed.
- 26.** As the work will have to be carried out in project and area in use the contractor shall ensure:-
a. That the normal functioning of Corporation activity is not affected as far as possible.
b. That the work is carried out in orderly manner without noise and obstruction to flow of traffic.
c. That all rubbish etc. is disposed off at the earliest and the place is left clean and orderly at the end of a each day's work.
d. The contractor shall ensure safety of his workers and others at site of work and shall be responsible for any consequence arising out of execution of the Repair and Maintenance work.
- 27. ESI:** - ESI is not applicable in the Chamoli Distt. of Uttarakhand therefore not applicable at VPHEP, Pipalkoti also.
- 28. SITE TO THE CONTRACTOR FREE FROM ENCUMBRANCE:**
Not Applicable.
- 29.** In case of any incident/accident during execute the work; the corporation shall not be liable for any claim.
- 30.** The work shall be executed as per BOQ / Scope of work and time to time instruction given by Engineer-in –charge for the aforesaid work.
- 30.** Contractor has to comply with all relevant labor laws regulations/rules etc. as may be applicable and amended time to time. Further, as per GCC clause 35.0.0 under head 'Contractors Liability & Insurance', Contractor has to take insurance for work, public liability & property liability as applicable before start of the work. These documents shall be submitted to EIC in line with GCC/SCC clauses. Contractor shall not be allowed to execute the work at site in absence (non submission) of aforesaid policy/policies and any delay in



completion period of contract due to non submission of aforesaid policies before start of the work shall be attributable to contractor.

31. The contractor shall make the payment directly to the bank accounts of their employees (including outsourced employees) through online transfer and ensure that all statutory deductions are deposited timely with the respective organization. Further, contractor at the time of submission of bill(s) shall submit (i) proof for the details of salary payment (of prevailing minimum wages) of previous month (ii) details along with dates in respect of necessary statutory payments of each employee (including outsourced employees) deposited with the respective organization like ESIC, EPFO etc.

The payment of next bill will be done to the contractor only on submission of above documents.

32. **COMPLIANCES OF VARIOUS PROVISIONS UNDER THE LABOURS LAWS (CLAUSE 17.0.0 OF GCC):**

- (i) Contractors shall have to obtain valid license under the Contract Labour (Regulation & Abolition) Act 1970 and Contract Labour (Regulation & Abolition) Rules 1971 in Form VI.
- (ii) The contractor shall submit an application form with requisite details along with form II for issue of form III through Engineer in charge (EIC) before commencement of work.
- (iii) On receipt of the required information the Principal Employer/P&A Department shall issue Form III, which shall be submitted by the contracting establishment to appropriate Government as notified from time to time for issue of Labour License. Subsequent to issue of Labour License by the Licensing Authority, photocopy of the same shall be provided to P&A Department/Principal Employer and Engineer in Charge (EIC) for their record and reference before the release of payment against any Running Account Bill.
- (iv) The contractor shall submit proof of PF code/ESI Code/Group insurance/GST and PAN allotted to him under the relevant Acts to P&A Department and Principal Employer /Engineer in Charge (EIC) before commencement of work.
- (v) Every contractor shall, as may be practicable, make disbursement of wages in a mode otherwise than in cash and inform the Principal Employer electronically the amount so paid by such mode. Provided that where it is not practicable to disburse such payment otherwise than in cash, then it shall be disbursed in the presence of a representative duly authorized by the Principal Employer and it shall be the duty of such representatives to certify the amount so paid as wages.
- (vi) In order to ensure statutory compliance of PF & ESI, payment of minimum wages, the contractor shall submit copy of PF/ESI challan, ECR sheet along with the attendance sheet (Form D) and wage register (Form B) and details of the PF & ESI account of individual worker for the preceding month to Engineer in Charge (EIC). The EIC shall route the same to the F&A department through P&A department for the release of payment. An undertaking by the contractor for Compliance of the provision of Contract labour (Regulation & Abolition) Act, Rules and other laws as applicable should also be given every month.
- (vii) Mode of payment in respect of Contract Workers engaged by contractor of THDC- through cheque or by crediting the wages in the bank account of the worker by the contractor himself or his nominee on or before 7th of every month.
- (viii) Principal Employer (THDC India Limited) shall have the right to deposit the Workmen's compensation in case of a contractor does not settle the same within seven days of its becoming due and deduct from Running Accounts bills of the Contractor without any further correspondence.
- (ix) Contractors/EIC/P&A Deptt. (THDCIL) to ensure the compliances of Statutory provisions of various Labours Laws such as the Code on Wages 2019 and the Interstate Migrant Workmen Act 1979.

33. In additions to the provisions provided in clauses related to labour laws in General Conditions of Contract, the following provisions shall hold good.

The contractor shall be liable to make payments to all his employees and shall comply with labour laws. If the OWNER is held liable as "PRINCIPAL EMPLOYER" to pay contribution etc. under E.S.I, P.F. Act, or any other legislation of Government or of Court decision, in respect of the employee of the contractor, then the amount of the such contribution so paid by the OWNER, shall be recovered from contractor.

34. TDS as applicable shall be deducted as per rule from RA bills.



- 35. BILL TRACKING SYSTEM (BTS):-** Vendor/Supplier/Contractor/Services provider shall obtain the user ID and password from Engineer-in-Charge (EIC) of Executing Department of THDCIL by submitting request against the PO/LOA/Work Order/MOU. After login into system i.e. <http://210.212.84.189/thdcbts>, Vendor/Supplier/Contractor/Service provider can view the copy of PO/LOA/Work order /MOU, movement of bill and details of payment in the system. Vendor/Supplier/Contractor/Services provider shall upload the information of invoice for the due payment on the above web site and submit to Engineer-in-charge. However, the bill along with all required documents (hard copies) as per requirement of PO / LOA / Work order / MOU / NIT is to be submitted by Vendor/Supplier/Contractor/Services provider simultaneously to EIC/THDCIL.
- 36.** In the event of two or more bidders quote the same BID price (the Tie BID), the selection of successful bidder shall be carried out as per following preferential manner:-
- (i) MSE owned by SC/ST category women.
 - (ii) MSE owned by SC/ST- Category
 - (iii) MSE owned by women Entrepreneur
 - (iv) MSE registered agency
 - (v) General Category
- In case of Tie bid in any of the above preferential manner, then THDCIL reserves the right to award the work to any of the lowest bidder based on qualification of bidder. No correspondence from bidder shall be entertained in this regard. Further, THDCIL may select the successful bidder by draw procedure (Annexure –P) amongst the tie bidders, which shall be conducted with prior notice, in the presence of the tie bidders who choose to attend.
- 37. EMS and OHSAS Certified Project**
- (a) VPHE Project Pipalkoti of THDC India Limited, being EMS and OHSAS Certified Project, it is the responsibility of Contractor to comply with all rules, regulations, obligations related to EMS and OHSAS Certification and also to comply with the requirements of THDCIL Safety manual. Contractor can obtain the copy of EMS & OHSAS documents from Management Representative (VPHEP) and can obtain copy of Safety Manual from Safety Officer, VPHEP.
 - (b) Contractor will ensure that all hazardous wastes/ byproducts generated due to their activities will be disposed off in environmentally favorable condition and as per guidelines/laws/rules of concerned authorities. Contractor will not dispose any hazardous waste in THDC India Limited area and will take away such item for reuse/recycle/disposal as per guidelines/ laws/ rules of concerned authorities.
 - (c) Contractor will obtain, review, understood and communicate all the environmental aspects/OH&S hazards and risks, EMS and OH&S objectives targets & programmes and EMS and OH&S OCPs to all concerned working here in THDC premises and will try to carry out activities in such conditions, so that there is no deviation from planned arrangements and will also extend full support in achieving the environmental objectives and targets related to the activities performed by aforesaid Company/ Firm/ Establishment.
 - (d) Contractor will extend full support in carrying out mock drills related to emergency situations. Contractor will take necessary correction and corrective action on any internal or external communication received for the activities carried out by them; on findings of such drills; on any deviation identified from planned arrangements.
- 38.** The copies of requisite document/certificates shall be self attested by the bidder while submitting the bid. However, the original documents/certificates shall be produced by the bidder for verification, if required by the Owner at any time. Further, the bidder shall be required to furnish a declaration as per Annexure – O along with his bid.
- 39.** All Taxes mentioned in GCC/SCC etc. shall be dealt as per GST Act. 2017.
- 40.** Contractor should submit Tax Invoice/Bill against work done in the manner of GST Act.
- 41. DELAY IN SIGNING OF AGREEMENT / SUBMISSION OF PERFORMANCE SECURITY DEPOSIT.**
- In case of delay in signing of the Contract Agreement is caused due to non submission of the Performance Security within the stipulated time as mentioned in the LOA, a penalty shall be deducted from the RA bill (s) of the contractor as per the slabs given below. However at any point of time THDCIL shall have the right to invoke the tender clause for forfeiture of EMD.



Contract value (in Rs.)	Min. Penalty per week or part thereof (in Rs.)	Max. Penalty (in Rs.)
Upto 5 lacs	500	2500
>5 lacs to 10 lacs	750	5000
>10 lacs to 20 lacs	1500	10000
>20 lacs to 1Cr.	2000	20000
>1 Cr. to 5 Cr.	10000	1.0 lacs
>5 Cr. To 10 Cr.	25000	2.5 lacs
>10 Cr. To 100 Cr.	50000	5.0 lacs
>100 Cr. To 1000 Cr.	2.0 lacs	20.0 lacs
>1000 Cr.	5.0 lacs	50.0 lacs

Note:

- i) For imposing the penalty (as above), delay period shall be considered as the period of delay in submission of performance security or in signing of contract agreement, whichever is lower. The period for submission of performance security and signing of Contract Agreement shall be as specified in the tender document.
 - ii) In case of B.G. towards performance security, the date of submission of performance security shall be considered as the date on which communication by email/courier along with copy of B.G. is received by THDCIL on the address mention in the tender document.
 - iii) In case of submission of performance security in other acceptable modes, the date of submission of performance security shall be considered the date of receipt of the performance security by THDCIL on the address mention in the tender document
- 42.** Refer clause no 4.0 PERFORMANCE SECURITY of GCC; the successful bidder for due performance of contract, as specified in letter of Award, shall furnish Performance Security of three percent (3%) of the contract sum in any one of the forms described in such clause for PERFORMANCE SECURITY in GCC. PS shall be submitted by bidder in any one of the form of Pay Order, Demand Draft/irrevocable Bank Guarantee or online NEFT/RTGS only. Clause 4.1.1 (c) & (d) of G.C.C stand deleted
- 43.** EMD shall be submitted by bidder in any one of the form of Pay Order, Demand Draft/irrevocable Bank Guarantee or online NEFT/RTGS only. Clause 1.31.1 (d) & (e) of information and instruction to bidders stand deleted.
- 44.** These special conditions of contract supersede the General Conditions of Contract to the extent mentioned herein above.



Section – VI

CONTRACTOR'S LABOUR REGULATION



Section – VI
CONTRACTOR’S LABOUR REGULATION:
(Under condition of clause no. 17.11.0 of GCC)

1. Definition: - In these regulations, unless otherwise expressed or indicated the following words and expression shall have the meaning hereby assigned to them:
- (a) “Labour” means workers employed by a contractor directly or indirectly through a subcontractor, or by an agent on his behalf.
 - (b) “Fair Wages” mean wages, which shall include wages for weekly day of rest and other allowances, whether for time or piece work, after taking into consideration prevailing market rates for similar employments in the neighborhood but shall not be less than the minimum rates of wages fixed under the payment of minimum wages Act.
 - (c) “Contractor” for the purpose of these regulations shall include an agent of subcontractor employing labour on the work taken on contract.
 - (d) “Inspecting Officer” means any Labour Enforcement Officer, or assistant Labour Commissioner of the Chief Labour Commissioner’s Organisation.
 - (e) “Form” means a form appending to these regulations.

2. Notice of Commencement:

The contractor shall within SEVEN days of commencement of the work furnish in writing to the inspection officer of the area concerned the following information:-

- (a) Name and situation of the work.
- (b) Contractor’s name and address.
- (c) Particulars of the Department for which the work is undertaken.
- (d) Name and address of the sub contractor as and when they are appointed.
- (e) Commencement and probable duration of work.
- (f) Number of worker’s employed and likely to be employed.
- (g) “Fair Wages” for different categories of workers.

(i) Number of hours of work which shall constitute normal working day:-

Normal working hours which shall constitute a normal working day for an adult shall be NINE hours. The working day of an adult worker shall be so arranged that inclusive of interval, if any for the rest it shall not spread over more than twelve hours on any day. When adult worker is made to work for more than NINE hours on any day or for more than FORTY NINE hours in any week he shall, in respect of overtime work, be paid wages at double the ordinary rate of wages.

(ii) Weekly Day of Rest:-

Every worker shall be given a weekly day of rest, which shall be fixed and notified at least TEN days in advance. A worker shall not be required or allowed to work on the weekly rest day unless he has or will have a substituted rest day on one of the five days immediately before or after the rest day provided that no substitution shall be made which will result in the worker working for more than ten days consecutively without a rest day for a whole day. When in accordance with the foregoing provisions a worker works on the rest day and has been given substituted rest day at the overtime rate of wages.

NOTE :-

The expression ordinary rate of wages means the fair wage the worker is entitled to. Display of notice regarding wages, weekly Day of Rest etc. The contractor shall before he commences his work on condition in conspicuous places on the works, notice in English and in the local Indian language, spoken by majority of workers, giving the rate of fair wages, the hours of work for which such wages are payable the weekly rest days workers are entitled to and name and address of the inspecting officer. The contractor shall send a copy each of such notices to the inspecting officers.

Fixation of wages period: The contractor shall fix wage period in respect of which wages shall be payable, No wage period shall normally exceed one week.

Payment of wages :

- I. Wages due to every worker shall be paid to him direct. All wages shall be paid in current coin and currency or in both.
- II. Wages of every worker employed on the contract shall be paid where the wage period is one week within THREE days from the end of the wage period and in any other case before the expiry of the 7th day or 10th day from the end of the wage period accordingly as the number of the workers do not exceed 1000 or exceeds 1000



- III. When the employment of any worker is terminated by or on behalf of the contractor, the wages earned by him shall be paid before expiry of the day succeeding the one on which his employment is terminated.
- IV. Payment of the wages shall be made at the work site on a working day except when the work completed before expiry of the wages period, in which case final payment shall be made at the work site within 48 hours of the last working day and during normal time.
- V. The contractor shall comply with section 21 and other relevant section of contract labour & (Regulation and Abolition) Act 1970 while making the labour payment.

7. Register of workman :

A register of workman shall be maintained in the form appended to these regulation and kept at the work site or as near to it as possible and the relevant particular of every workmen shall be entered therein within THREE days of his employment.

8. Employment Card :

The contractor shall issue an employment card in the form appended to these regulations to each worker on the day of work or entry into his employment. If a worker already has any such a card with him issued by the previous employer, the contractor shall merely endorse that Employment Card with relevant entries. On termination of Employment the employment card shall again be endorsed by the contractor and returned to the worker.

9. Labour Statistics :

The contractor shall report monthly and shall cause sub-contractors to report in the like manner within five days after the close of the each calendar month, on forms to be approved by the Engineer-in-Charge, the number of person on their respective pay rolls and such other additional information as may be required by the Engineer-in-Charge. He shall furnish to the Engineer-in-Charge, if required, the name and addresses of all such persons on the work. The contractor shall, as far as possible, employ local (skilled and unskilled) staff if found suitable.

10. Convict Labour :

In connection with the performance of work under this contract, the Contractor, shall not employ any person being tried in the court of criminal offence or any person who has been convicted for criminal offence.

11. Non-Discrimination in the Employment :

In connection with the performance of work under this contract, the contract shall not discriminate against any employee or applicant for employment, because of race, caste, creed or colour or national origin, and further agrees to insert the foreign provision in all sub-contracts hereunder.

12. Employment of labour of Other Contractors:

If the contractor takes away any labour brought and employed by other Contractor of the Corporation working on the same project, he shall be liable to pay compensation equal to the profit the original Contractor would have made, if the labour would have continued with him and he will also have to return the labour thus employed. The decision of the Engineer-in-Charge in this regard shall be final and binding on the contractor.

13. Register of the Wages etc.:

- i. A register of Wages-Cum-Muster roll in the form appended to these regulations shall be maintained and kept at the work site or as near to it as possible.
- ii. A wages slip in the Form appended to these regulations shall be issued to every worker employed by the contractor at least a day prior to disbursement of wages.

14. Fines and deductions which may be made from wages:

- i. Wages of worker shall be paid to him without any deduction of any kind except the following:
 - (a) Fines.
 - (b) Deduction for absence from duty, i.e. from the place of his employment he is required to work. The amount of deduction shall be in proportion to the period for which he was absent.
 - (c) Deduction for damage to or loss of goods expressly entrusted to the employed person for custody, or for loss of money which he is required to account for where such damage or loss is directly attributable to his neglect or default.
 - (d) Deductions for recovery of advances or for adjustment of overpayment of wages, Advance granted shall be entered in register, and
 - (e) Any other deduction which the Corporation may form time to time allow.



- ii. No fines shall be imposed on any worker say in respect of such acts and omissions on his part as have been approved by the Chief Labour Commissioner.
- iii. No fines shall be imposed on any worker and no deduction for damage or loss shall be made from his wages until the worker has been given an opportunity of showing cause against such fines or deductions.
- iv. The total amount of fines which may be imposed in any one wage period on a worker shall not exceed an amount equal to three paise in a rupee of the wages payable to him in respect of that wage period.
- v. No fine imposed on a worker shall be recovered from him in installment, or after expiry of sixty days from the date on which it was imposed. Every fine shall be deemed to have been imposed on the day of the act or omission in respect of which it was imposed.
- vi. The contractor shall maintain both in English and the local Indian Language a list approved by the Chief Labour Commissioner clearly stating the act and omissions for which penalty or fine may be imposed on a workman and display it in good condition in a conspicuous place on the work site.
- vii. The Contractor shall maintain a register of fines and the register of deduction for damage or loss in the Forms appended to these regulations which should be kept at the place of work.

15. Register of Accidents

The contractor shall maintain a register of accidents in such form as may be convenient at the work place but the same shall include the following particulars:

- (a) Full particulars of the labourers who met with accident.
- (b) Rate
- (c) Sex
- (d) Age
- (e) Nature of accident and cause of accident.
- (f) Time and Date of accident.
- (g) Date and time when admitted in hospital.
- (h) Date and discharge from the hospital.
- (i) Period of treatment and result of treatment.
- (j) Percentage of loss of earning capacity and disability as assessed by Medical Officer.
- (k) Claim required to be paid under workmen's Compensation Act.
- (l) Date of payment of compensation.
- (m) Amount with details of the person to whom the same was paid.
- (n) Authority by whom the compensation was assessed.
- (o) Remarks.

Preservation of Registers :

The Register of Workman and Register of Wages-cum-Muster Roll required to be maintained under these Regulations shall be preserved for 3 years after the date on which the last entry is made therein.

Enforcement :

The inspecting officer shall either on his own motion or on a complaint received by him carry out investigation, and send a report to the Engineer-in-Charge specifying the amounts representing workers dues and amount of penalty to be imposed on the contractor for breach of these Regulations that have to be recovered from the Contractor, indicating full details of the recoveries proposed and the reason therefore. It shall be obligatory on the part of the Engineer-in-charge on receipt of such a report to deduct such amounts from payments due to the contractor.

Disposal of the amount recovered from the Contractor:

The Engineer-in-Charge shall arrange payment to workers concerned within FORTY FIVE days from receipt of a report from the inspecting officer except in cases where the contractor had made an appeal under Regulations 16 of these Regulations. In case where there is an appeal, payment of workers dues would be arranged by the Engineer-in-Charge, wherever such payments arise, within THIRTY DAYS from the date of receipt of the decision of the Regional Labour Commissioner (R.L.C.)

Welfare Fund :

All money that are recovered by the Engineer-in-Charge by way of workers dues which could not be disbursed to workers within the time limit prescribed above due to reasons such as whereabouts of workers not being known death of a worker etc. and also amounts recovered as penalty, shall be



credited to a fund to be kept under the custody of the Corporation for such benefit and welfare of workmen employed by contractors.

Appeal against decision of inspecting officer :

Any person aggrieved by a decision of the inspecting officer may appeal against such decision to the Regional Labour Commissioner concerned within THIRTY days from the date of the decision, forwarding simultaneously a copy of his appeal to the Engineer-in-Charge. The decision of the Regional Labour Commissioner shall be final and binding upon the Contractor and the workmen.

Representation of Parties :

- (I) A workman shall be entitled to be represented in any investigation or enquiry under these regulations by an officer of a registered trade union of which he is a member or by an officer of a Federation of Trade Union to which the said trade union is affiliated or where the workman is not a member of any registered trade union by an officer of a registered Trade Union, connected with or by any other workman employed in industry in which the worker is employed.
- (II) A Contractor shall be entitled to be represented in any investigation or enquiry under these Regulations by an officer of an association of Contractors of which he is a member or by an officer of a federation of associations of Contractors to which the said association is affiliated or where the contractor is not a member of any association of contractors, by an officer of association of employer connected with or by any other employer engaged in the industry in which the contractor is engaged.
- (III) No party shall be entitled to be represented by a legal practitioner in any investigation or enquiry under these Regulations.

Inspection of Book and other Documents:

The contractor shall allow inspection of the registers and other documents prescribed under these regulation by inspecting officers and the Engineer-in-Charge or his authorized representative at any time and by the worker or his agent on receipt of due notice at a convenient time.

Interpretation etc.:

On any question as to the application, interpretation or effect of these Regulations, the decision of the Chief Labour Commissioner or Deputy Chief Labour Commissioner (central) shall be final and binding.

Amendments :

Central Government may from time to time add to or amend these Regulation and issue such directions as it may consider necessary for the proper implementation of these Regulations or for the purpose of removing any difficulty which may arise in the administration thereof.



WAGE SLIP

(Regulation 9)

- i. Name of Contractor _____
1. Name of the workers with Father's/husband's name _____
2. Nature of employment _____
3. Wage Period _____
4. Rate of wage payable _____
5. Total attendance/unit of work done _____
6. Dates on which overtime worked _____
7. Overtime wages _____
8. Gross wages Payable _____
9. Total Deduction _____
(Including nature of deductions)
10. Net wages payable _____

Contractor's Signature/
Thumb impression

Employee's Signature/
Thumb impression



Model Rules of Labour Welfare
(Under condition of clause no. 17.9.0 of GCC)

1- Definitions:

- (a) "Workplace" means place at which on an average, twenty or more workers are employed.
(b) "Large Workplace" means a place at which, on average 500 or more workers are employed.

2- First Aid :

At every workplace, there shall be maintained in a readily accessible place first aid appliances including an adequate supply of sterilized dressing and sterilized cotton wool as prescribed in the Factory Rules of the state in which the work is carried on. The appliances shall be kept in good order and in large work-place they shall be placed under the charge of a responsible person who shall be readily available during working hours. At large workplace, where hospital facilities are not available within easy distance of the work First Aid post shall be established and be run by a trained compounder. Where large workplaces are remotely situated and far away from regular hospital, an indoor ward shall be provided with one bed for every 250 employees. Where large workplace are situated in cities towns or in their suburbs and not considered necessary owing to proximity of city or town hospitals, suitable transport shall be provided to facilitate removal of urgent cases to these hospitals. At other workplace, some conveyance facilities shall be kept readily available to take injured person or persons suddenly taken seriously ill, to the nearest hospital. At large workplaces there shall be provided and maintained an ambulance room of the prescribed size containing the prescribed equipment and in the charge of such medical and nursing staff as may be prescribed for this purpose. The relevant provisions of the factory Rules of the State Government of the area where the work is carried on may be taken as the prescribed standard.

3- Accommodation for Labour:

The contractor shall during the progress of the Works provide erect and maintain necessary temporary living accommodation and ancillary facilities for labour at his own expense and to standards and scales as approved by the Engineer-in-Charge.

4- Drinking Water:

In every workplace, there shall be provided and maintained at suitable places easily accessible to labour of sufficient supply of cold water fit for drinking. Where drinking water is obtained from an intermittent public water supply each workplace shall be provided with storage where drinking water shall be stored. Every water supply storage shall be at a distance of not less than 15 meters from any latrine drain or other source of pollution. Where water has to be drawn from an existing well which is within such proximity of latrine drain or any other source of pollution, the well shall be properly chlorinated before water is drawn from it for drinking. All such wells shall be entirely closed in and be provided with a trap door which shall be dust and waterproof. A reliable pump shall be fitted to each covered well, the trap door shall be kept locked and opened only for cleaning or inspection which shall be done atleast once a month.

5- Washing and Bathing places :

Adequate washing and bathing places shall be provided separately for men and women. Such places shall be kept in clean and drained condition.

6- Scale of Accommodation in Latrines and Urinals:

There shall be provided within the precincts of every workplace latrines and urinals in an accessible place and the accommodation separately for each of these shall not be less than at the following scale:

	<u>No. of</u>
	<u>seats</u>
(a) Where number of persons do not exceed 50	02
(b) Where number of persons exceed 50 but do not exceed 100	03
(c) For additional persons per 100 or part thereof	03

In particular cases, the Engineer-in-Charge shall have the power to increase the requirement where necessary.

7- Latrines and Urinals :

Except in workplace provided with water flushed latrines connected with a water born sewage system, all latrines shall be provided with receptacles on dry-earth system which shall be cleaned at



least four times daily and at least twice during working hours and kept in a strictly sanitary condition. Receptacles shall be tarred inside and outside at least once a year. If women are employed separate latrine and urinals screened from those for men and marked in the vernacular in conspicuous letters "For Women only" shall be provided on the scale laid down in rule 6. Those for men shall be similarly marked "For Men only" A poster showing the figure of a man and of a Woman shall also be exhibited at the entrance to latrines for each sex.

There shall be adequate supply of water close to latrines and urinals.

8- Construction of Latrines:

Inside walls shall be constructed of masonry or other non-absorbent material and shall be cement washed inside at least once a year. The dates of cement washing shall be noted in a register maintained for the purpose and kept available for inspection Latrines shall have at least thatched roof.

9- Disposal of Excreta:

Disposal of excreta by incineration at the workplace shall be made by means of a suitable incinerator approved by the local medical health and municipal or cantonment authorities. Alternatively excreta may be disposed off by putting a layer of night soil at the Bottom of pucca tank prepared for the purpose and covering it with a 15 cm layer of waste or refuse and then covering it with a layer of earth for fortnight (when it will turn into manure). The Contractor shall, at his own expense, carry out all instructions issued to him by the Engineer-in-Charge to effect proper disposal of soil and other conservancy work in respect of Contractor's work people or employees on the Site, The Contractor shall be responsible for payment of any charges which may be levied by municipal or cantonment authority for execution of such work on his behalf.

10- Provision of shelters during rest :

At every workplace there shall be provided free of cost four suitable sheds two for meals and two others for rest, separately for use of men & women Labour. Height of each shelter shall not be less than 3 meters from floor-level to lowest part of roof. Sheds shall be kept clean and the space provided shall be on the basis of at least 0.5 sq.m. per head.

11- Creches:

At place at which 20 or more women workers are ordinarily employed there shall be provided at least one hut for use of children under the age of 6 years belonging to such women. Huts shall not be constructed to a standard lower than that of thatched roof, mud floor and wall with wooden planks spread over mud floor and covered with matting. Huts shall be provided with suitable and sufficient openings, for light and Ventilation. There shall be adequate provision of sweepers to keep the places clean. There shall be two Dais in attendance. Sanitary utensils shall be provided to the satisfaction of local medical, health and municipal of cantonment authorities. Use of huts shall be restricted to children, their attendants and mothers of children.

Where the number of women workers is more than 25 but less than 50, the contractor shall provide at least one hut and one Dai to look after children of women workers. Size of crèche(s) shall vary according to the number of women workers employed. Crèches shall be properly maintained & necessary equipments like toys etc. provided.

12- Canteen :

A cooked food canteen on moderate scale shall be provided for the benefit of workers wherever it is considered necessary.

13- Planning, Setting and erection of the above mentioned structures shall be approved by the Engineer-in-Charge and the whole of such temporary accommodation shall at all times during the progress of the works be kept tidy and in clean and sanitary condition to the satisfaction of the Engineer-in-Charge and at the contractor's expense. The contractor shall confirm generally to sanitary requirements of local medical, health and municipal or cantonment authorities and at all times adopt such precautions as may be necessary to prevent soil pollution of the Site. On completion of the Works the whole of such temporary structure shall be cleared away, all rubbish burnt, excreta or other disposal pits or trenches filled in and effectively sealed off and the whole of site left clean and tidy to the entire satisfaction of the Engineer-in-Charge and at the Contractor's expenses.

14- Anti-malarial precautions:

The contractor shall at his own expense, conform to all anti malarial instructions given to him by the Engineer-in-Charge, including filling up any borrow pits which may have been dug by him.



15- Enforcement :

The inspecting officer mentioned in the contractors Labour Regulations or any other officer nominated in his behalf by the Engineer-in-Charge shall report to the Engineer-in-Charge all cases of failure on the part of the contractor and or his sub-contractors to comply with the provisions of these Rules either wholly or in part and the Engineer-in-Charge shall impose such fines and other penalties as are prescribed in the conditions.

16- Interpretations etc.:

On any question as to the application, interpretation or effect of these Rules, the decision of the Chief Labour Commissioner or Deputy Chief Labour Commissioner (central) shall be final and binding.

17- Amendments :

Government may from time to time add to or amend these rules and issue such directions as it may consider necessary for the proper implementation of these Rules or for the purpose of removing any difficulty which may arise in the administration thereof.



SAFETY REQUIREMENTS

(Under condition of clause no. 17.10.0 of GCC)

1. It shall be the complete responsibility of the Contractor to meet the safety requirements on the works. The provisions detailed herein under are supplementary to safety requirements as stipulated in Central, State or local bodies laws, rules regulations, applicable for the time being and amended from time to time. Where the provisions conflict, with the aforementioned laws etc. by reason of amendment or by other cause the stipulations of the aforementioned laws etc. shall govern. The Contractor has also to comply all the requirements as mentioned in THDCIL's Safety, Health and Environment Manual' (SHE) of Mar'2017.
2. In order that the accident prevention programme may function properly, the Contractor shall provide a full time safety Engineer. The safety Engineer shall report and be responsible to the highest ranking job managerial executive or his designated representative. The duties of the safety Engineer including the following :

He shall:

- (i) Be responsible for coordinating the safety programme.
 - (ii) Act in an advisory capacity on all matters pertaining to safety for the management, superintendents, foremen, purchasing department, Engineering department and sub-contractors.
 - (iii) (a) Make personal investigation of all fatal, serious and unusual accidents.
(b) Check corrective action taken by the supervisors to eliminate accident causes.
 - (iv) Make inspections for the purpose of detecting and correcting unsafe conditions and safe work practices (Records to be maintained and filled for future reference)
 - v) Make certain that all central Government, State Government or local laws and ordinance, THDCIL's Safety, Health and Environment Manual' (SHE) are complied with.
 - (vi) Initiate activities that will stimulate and maintain the interest of all supervisors and employees in safety matters.
 - (vii) Prepare an agenda for and attend safety meetings.
 - (viii) Appoint a safety steward for each craft or location.
 - (ix) Confer with the insurance company Engineer on safety problems and accompany him on surveys on the job operator, initiated by him.
3. Suitable scaffolds shall be provided for workmen for all work that cannot safely be done from the ground, or from solid construction. Portal ladders are not recommended more than 4 meters. They shall be placed at an angle of 45⁰ from horizontal. Both top and bottom should be secured to prevent displacement.
 4. Scaffolding or staging more than 2 meters above the ground or floor, swing or suspended from an overhead support or erected with stationary support shall have a guard rail properly attached, bolted, braced and otherwise secured as least 1 meter high above the floor or platform or such scaffolding or staging and extending along the entire length of the outside and ends thereof with only such opening as may be necessary for the delivery of materials. Such scaffolding or staging shall be so fastened as to prevent it from swaying from the building or structure and guarded by railing from all opening except the entrance.
 5. Working platform gangways, and stairways shall be so constructed that they do not sag unduly or unequally. And if a height of a platform/ gangway/ stairway is more than 1.2 meters or more above the adjacent floor or ground level shall be guarded by railing on all open sides, except where there is entrance to the platform.
 6. Every opening in floor of a building or in a working platform shall be provided with suitable means to prevent fall of persons or materials by providing suitable fencing or railing with a minimum height of 1 meter.
 7. Safe means of access shall be provided to all working platform and other working places. Every ladder shall be securely fixed. Portal ladders are not recommended for flight above 4 meters. Adequate precautions shall be taken to prevent danger from electrical equipment. No material on any of the sites shall be so stacked or placed as to cause danger or inconvenience to any person or the public. The Contractor shall provide all necessary fencing and lights to protect public from accident & shall be bound to bear expenses of defense of every suit, action or other proceeding at law that may be brought by any person for injury sustained owing to neglect of the above precautions and to pay any damages and cost which may be awarded in such suit, action or



- proceeding to any such person or which may with the consent of the Contractor be paid to compromise any claim by any such person.
8. **Excavation and Trenching** : All trenches, 1.5 meters or more shall at all times be supplied with at least one ladder for each 20 meters in length of fraction thereof, Ladder shall be extended from bottom of trench at least 1 meter above surface of the ground. Sides of trench which is 1.5 meter or more in depth shall be stepped back to give suitable slope or securely held by timber bracing so as to avoid the danger of sides collapsing. Excavated material shall not be placed within 1.5 meter of edge of trench or half of depth of trench whichever is more. Cutting shall be done from top to bottom. Under no circumstances shall undermining or undercutting be done.
9. Before any demolition work is commenced and also during the precise of the work:
- (a) All roads and open areas adjacent to the work Site shall either be closed or suitably protected.
 - (b) No electric cable or apparatus which is liable to be a source of danger over a cable or apparatus used by operator shall remain electrical charged
 - (c) All practical steps shall be taken to prevent danger to persons employee from risk or fire or explosion or flooding. No floor, roof or other part of building shall be so overloaded with debris or materials as to render it unsafe.
 - (d) Care must be taken not to damage the existing structure/ materials. While executing the proposed works, any damage if caused should be rectified by the contractor at his cost so as to restore the structure/ materials as they existed earlier. Contractor may also have to pay adequate and immediate compensation for personal injury/lose to property at the discretion of the Engineer-In charge.
10. All necessary personal safety equipment as considered adequate by the Engineer-in-Charge shall be available for use of persons employed on the site and maintained in a condition suitable for immediate use and the Contractor shall take adequate steps to ensure proper use of equipment by those concerned.
- a. Workers employed on mixing asphaltic material cement and lime mortars concrete shall be provided with protective footwear and protective goggles.
 - b. Those engaged in handling any material which is injurious to eyes shall be provided with protective goggles.
 - c. Those engaged in welding works shall be provided with welders protective eye shields.
 - d. Stone breakers shall be provided with protective goggles and protective clothing and seated at sufficiently safe interval
 - e. When workers are employed in sewers and manholes which are in use, the contractor shall ensure that manhole covers are opened and manholes are ventilated at least for an hour before workers are allowed to get into them. Manholes so opened shall be cordoned off with suitable railing and provided with warning signals or boards to prevent accident to public.
 - f. The Contractor shall not employ men below the age or 18 and women on the work of painting with products containing lead in any form. Whenever men above the age of 18 are employed on the work of lead painting, the following precautions shall be taken:
 - i. No paint containing lead or lead products shall be used except in the form of paste or readymade paint.
 - ii. Suitable face masks shall be supplied for use by workers when paint is applied in the form of spray or a surface having lead paint dry rubbed and scrapped.
 - iii. Overalls shall be supplied by the contractor to workmen and adequate facilities shall be provided to enable working painters to wash during and on cessation of work.
11. When work is done near any place where there is risk of drowning, all necessary equipment shall be provided and kept ready for use and all necessary steps taken for prompt rescue of any person in danger and adequate provision made for prompt first aid treatment of all injuries likely to be sustained during the coarse of the work.
12. Use of hoisting machines and tackle including their attachments anchorage and supports shall conform to the following:
- a.(i) These shall be of good mechanical construction sound material and adequate strength and free from patent defect and shall be kept in good working order and properly maintained.
 - (ii) Every rope used in hoisting or lowering materials or as a means of suspension shall be of durable quality and adequate strength and free from patent defects.



- b. Every crane driver or hoisting appliance operator shall be properly qualified and no person under the age of 21 years shall be in charge of any hoisting machine including any scaffold or give signals to operator.
 - c. In case of every hoisting machine and of every chain ring hook, shackle, swivel and pulley block used in hoisting or lowering or as means of suspensions, safe working load shall be ascertained by adequate means. Every hoisting machine and all gear referred to above shall be plainly marked with safe working load. In case of a hoisting machine with a variable safe working load each safe working load and the conditions under which it is applicable shall be clearly indicated. No part of any machine or of any geared equipment referred to above in the paragraph shall be loaded beyond safe working load except for the purpose of testing.
 - d. In case of a Corporation's machine, safe working load shall be notified by the Engineer-in-Charge. As regards Contractor's machines, the Contractor shall notify safe working load of each machine to Engineer-in-Charge whenever he brings it to Site of work and get it verified by the engineer-in-Charge.
13. Motors, gearing, transmission, electric wiring and other dangerous parts of hoisting appliance shall be provided with efficient safeguards: hoisting appliances shall be provided with such means as will render to the minimum risk of accidental descent of load. Adequate precautions shall be taken to reduce to minimum risk of any part of a suspended load becoming accidentally displaced. When workers are employed on electrical installations whichever already energized including mats, working apparel such as glove, sleeves and boots, as may be necessary shall be provided. Workers shall not wear any rings, watches and carry keys or other materials, which are good conductors of electricity.
 14. All scaffolds, ladders and other safety devices mentioned or described herein shall be maintained in a safe condition and no scaffold, ladder or equipment shall be altered or removed while it is in use. Adequate washing facilities shall be provided at or near place or work.
 15. All operations involving handling, storage, transportation and use of explosive in surface as well as underground works shall be performed in accordance with all applicable central, State and municipal laws and ordinances as required by the concerned chief Inspector of Explosives, Government of India.
 16. The Contractor shall comply with the Indian Electricity Act and the Rules made there under. He will also comply with the Rules framed by the respective State Government and enforced by chief Electrical Inspector of the concerned State.
 17. The Contractor shall comply with the provisions laid down in the THDCIL's Safety, Health and Environment Manual' (SHE), CEA Regulation, B&OCW Act and shall also follow the safety rules and regulations as stipulated in the state rule where work is done.
 18. These safety provisions shall be brought to the notice of all concerned by display on a notice board at a prominent place at the workshop. Persons responsible for ensuring compliance with the safety code shall named therein by the contractor.
 19. To ensure effective enforcement of the rules and regulations relating to safety precautions arrangements made by the Contractor shall be open to inspection by the Engineer-in-Charge or his representatives and the inspecting officers as defined in the Contractors Labour Regulation.
 20. Notwithstanding the above condition 1 to 19 the Contractor is not exempted from the operation of any other Act/Rule applicable at place of work. All these conditions shall also be applicable in conjunction with THDCIL's Safety, Health and Environment Manual' (SHE) of Mar'2017.



SECTION – VII

ANNEXURE



Details of Bank Account

(Refer clause no 51.3.6 of GCC)

(To be submitted by the bidder on letter head)

Dated

**Sr. Manager (C&MM)
THDC INDIA LIMITED,
VPHEP, Alaknandapurma Siaysain (Jaisal), Pipalkoti
Chamoli, Uttarakhand (India)**

Dear Sir,

Sub:

We, hereby authorize THDC INDIA Ltd to make all our payments through Electronic Fund Transfer System. The details for facilitating the payments are given below:

1. Name of the beneficiary:
2. Account
3. Address
4. Contact person
5. Telephone no. (with STD code)
6. E-mail ID
7. Bank particulars
 - A. Bank name
 - B. Bank account number, type of account
 - C. Bank telephone no. (with STD code)
 - D. Branch address
 - E. Bank fax no (with STD code)
 - F. Branch code
 - G. NEFT Code
 - H. MICR code of the Bank Branch

Signature of the authorized representative

Name_____

Designation_____

Name of the Bidder_____

Stamp of the Bidder_____



FORM FOR POWER OF ATTORNEY

(Refer clause no 1.23.0 of Section-II-ITB)

(Notarized / non - judicial Stamp Paper)

Know all these presents that the undersigned, _____ of (Name) M/s _____

_____ (Name of the company) a company organized and existing under the laws of _____ and having its principal place of (Name of the Country) business at _____ (complete address)

does thereby make constitute and appoint Shri _____ (Name) of M/s _____ (a corporation organized and existing under the laws of _____ and having its principal (Name of the country)

place of business at _____) its true and lawful attorney in fact to enter into joint venture agreement / and to offer and submit bid to THDC INDIA LIMITED for the supply of goods and related services to the Tender no. **THDCIL/VPHEP/PKOTI/22-23/04** to make sign and deliver documents necessary for or incidental to the offering and submitting of such a quotation to negotiate, enter into, sign and deliver a contract with the said office based upon the said- bid ; and to do any and all other acts necessary for or incidental to the performance and execution of the powers herein expressly granted. Whereas the undersigned is fully authorized to deliver such power of attorney to above named person / company _____ in witness whereof, this power of attorney is duly signed on _____

Yours faithfully,

(Name of Company)

(Name of officer)

Signature of Mr. _____ attested.

Signature attested by



DECLARATION OF BIDDER

(To be submitted by the bidder on Letter Head along with Part-I)
Refer clause no 1.51.0 of Section-II –ITB

To,
THDC INDIA LIMITED,
VPHEP, Alaknandapurma Siaysain (Jaisal), Pipalkoti
Chamoli, Uttarakhand (India)
246472

Sub: - Construction of Rock fall protection barrier for B-Block colony at VPHEP.
(Tender No THDCIL/VPHEP/PKOTI/22-23/04)

Sir,

We undertake that:

1. In competing for (and if the award of work is made to us for execution) the above contract, we shall strictly observe the laws against fraud and corruption in force in India namely "*Prevention of Corruption Act, 1988*".
2. We are not under a declaration of ineligibility for corrupt and fraudulent practices or banned/debarred/suspended from transaction/business dealing by Ministry of Power (Govt. of India) or by THDC India Ltd. or appearing in the list of such bidders available on Central Public Procurement Portal (CPP Portal)

Date:

.....
(Signature of the authorized representative)

Name:

Designation:

Name of the agency.....

Stamp of the agency.....



NO DEVIATION CERTIFICATE
(Refer clause no. 1.33.0 of ITB, Section-II)

- 1.0 This is to certify that our offer is in complete conformity with your tender No. **THDCIL/VPHEP/PKOTI/22-23/04**. This is to expressly certify that our offer contains no deviation either Technical or Commercial in either direct or indirect form.
- 2.0 Any undeclared deviation coming into notice of the Owner shall be treated as withdrawn.

Signed by Authorized Signatory:

Name: _____

Designation: _____

Name of Bidder: _____

Date & Place: _____

Phone/ Fax/ Mobile/ Email: _____

Stamp & Seal: _____



TENDER FORM

(Refer clause no. 1.39.0 of ITB, Section-II)
(On Letter Head)

To,

THDC INDIA Ltd.
VPHEP, Alaknandapuram, Siyasain (Jaisal), Pipalkoti
Chamoli, Uttarakhand (India)

Sub:

1. We have read and examined the following tender documents relating to the Tender No. **THDCIL/VPHEP/PKOTI/22-23/04** dated for the works of **Construction of Rock fall protection barrier for B-Block colony at VPHEP.**

- I. a. Notice Inviting Tender
- b. Information & instruction to bidders
- c. General Conditions of Contract.
- d. Special Conditions of Contract.
- e. Amendment to above, if any.
- f. Warranty
- g. Schedule of quantities

II. Technical Specifications

III. Drawings

- 2. We hereby tender for execution of the works referred to in the documents mentioned in paragraph 1 above and the terms and conditions contained or referred to in the aforesaid documents and in accordance to all respects with the specifications designs, drawings and other details given therein and at the rates contained in Schedule of Quantities and within the period of completion.
- 3. We agree to keep this tender open for acceptance for 120 days from the due date of opening or extended date of opening thereof and also agree not to make any modifications in its terms and conditions of our own accord.
- 4. A sum of Rs is hereby forwarded in form of **RTGS/DD/BG/NEFT/MSE's certificate** towards earnest money. We agree if we fail to keep the validity of tender open, as aforesaid, or we make any modification in the terms and conditions of our tender on our own accords and/ or after the acceptance of our tender if we fail to commence the execution of the works as provided in the documents referred to in paragraph above, we shall become liable for forfeiture of our earnest money as aforesaid, and the Corporation shall without prejudice to any other right or remedy, be at liberty to forfeit the said earnest money absolutely. Should this tender be accepted, we agree to abide by any fulfill all the terms and conditions and provisions of the above mentioned tender documents.
- 5. We certify that the tender submitted by us is strictly in accordance with the terms, conditions, specifications etc. as contained in your document, referred to in paragraph as contained in your



document referred to in paragraph as contained in your tender documents, referred to in paragraph above and it is further certified that it does not contain any deviation to the aforesaid documents.

6. We have inspected and examined the site and its surroundings and have satisfied before submitting this tender in respect of the site conditions including but not restricting to the points as mentioned in **Section –II** “Information and Instructions for Bidders” which may influence or affect the work or cost thereof under this contract.

Signature alongwith Seal of Bidder

Name _____

Designation: _____

Date: _____

Postal Address: _____

E-mail: _____

Phone: _____

Witness:

Signature: _____

Name _____

Designation: _____

Phone: _____

Address: _____

E-mail: _____



WARRANTY FORM

(Refer clause no. 1.0.39 of ITB, Section-II)

(To be executed on non –judicial stamp paper in accordance with the stamp Act.)

To

M/s THDC INDIA Limited,
VPHEP, Alaknandapuram, Siyasain (Jaisal), Pipalkoti
Chamoli, Uttarakhand (India)

Subject: Bidder's Warranty against Tender No. **THDCIL/VPHEP/PKOTI/22-23/04 Dated:**
..... for the works of **Construction of Rock fall protection barrier for B-Block
colony at VPHEP.**

Dear Sirs,

THDC INDIA Ltd., **VPHEP** , having invited subject tender for the subject works to be executed at **VPHEP** We, M/s _____ (herein after referred to as the bidder) having its registered office at _____ being desirous of tendering in subject tender and having carefully studied all the tender documents consisting of Notice inviting Tender, Information and Instructions for bidders ,General conditions of contract, special conditions of contract Technical Specifications, Drawing (if any) time Schedule, Bill of Quantities, Local and site conditions.

We M/s _____ hereby, submit our tender and under take to keep our tender valid for a period of 120 days from the scheduled date/extended date of opening of tenders. “We hereby further under take that during the said period, we shall not vary/alter or revoke our tender during the validity period of our tender.

1. We are familiar with and undertaken to earnestly bill of quantities of the tender.
2. We have investigated the site and satisfied our self regarding the character of the work and local conditions that may effect the work or its performance.
3. We are satisfied that the work can be performed and completed required in the tender documents.
4. We accept all risks directly or indirectly.
5. We have no collusion with other contractors or with any other person in corporation to execute the said works according to the terms and conditions of the said tender.
6. We have not been influenced by any statement or promise of the terms and conditions of the Corporation but only by the tender documents.
7. We are financially solvent.
8. We have experience and competency to perform the contract to the satisfaction of the Corporation.
9. The statements submitted by the Contractor are true.
10. We are familiar with all general and special laws. Act, ordinances, Rules and Regulations of the Municipalities, District, State and Central Government that may effect the work, its performance or personnel employed therein. Should this tender be accepted, we also agree to abide by and fulfill and couple with all the terms, conditions and provision of the above mentioned tender documents except durations which have been specifically brought out in “Statement of deviations.”



Place :

Date :

Signature & Seal of the Bidder

(Duly authorized to sign the tender on
behalf of bidder)

Witness :

1. Name -----

Designation -----

Postal Address -----

2. - Name -----

Designation -----

Postal Address -----



Annexure-G

FORM FOR CONTRACT- AGREEMENT
(Refer clause no. 1.47.0 of ITB, Section-II)
(On Non Judicial Stamp paper of appropriate value)

This agreement is made on _____ day of _____ Two Thousand between THDC INDIA LIMITED,, a Joint Venture Company of Government of India and Government of Uttar Pradesh, registered and existing under the Laws of India and having its registered Office at Bhagarathi Bhawan (Top Terrace), Bhagarathi Puram, Tehri (Garhwal) PIN – 249001, Uttarakhand, India.(hereinafter referred to as the "Employer" which expression shall unless repugnant to the context or meaning thereof include its successors and permitted assigns) on the one part and M/s_____, a Company/ Corporation registered / incorporated under the Laws of_____/ Companies Act _____, having its registered office at_____ (hereinafter referred to as the "Contractor," which expression shall unless repugnant to the context or meaning thereof, include its successors and permitted assigns) of the other part.

WHEREAS THDC INDIA LIMITED for its Project..... (hereinafter called the Project) at..... had invited tenders vide No.for the work

And whereas M/s had participated in the above referred tendering vide their proposal no. dt. THDC India Limited accepted their proposal vide letter of award no.dt. and awarded the contract for to M/s and whereas M/s have unequivocally accepted to undertake the work as per terms and conditions mentioned herein and in contract documents attached herewith.

Now therefore this deed witnesseth as under:

ARTICLE 1.0 CONTRACT DOCUMENTS

1.1 The contract shall be performed strictly as per the terms and conditions stipulated herein and in the documents mentioned below incorporating amendments issued, if any, which are as fully a part of this contract as if herein setout verbatim or if not attached as if hereto attached.

- i) General conditions of contract and Special Conditions of contract.
- ii) Technical Specifications & Drawings
- iii) Schedule of items / Bill of quantities.
- iv) Agreed construction Schedule / Bar Chart
- v) Deployment of Plant & Equipment
- vi) Tender Form
- vii) Warranty Form
- viii) Letter of Award
- ix)

1.2 The contract documents constitute full and complete understanding between the parties and terms of these presents. The parties declare that in entering the contract, they do not rely upon any previous correspondence and representation, whether expressed or implied and whether written or oral or any inducement, understanding or agreement of any kind not included within the contract documents and all prior negotiations, discussions, representations and understandings not included herein stand annulled.



1.3 Any modification/ amendment to the Contract shall be affected only by a written instrument signed by the authorized representatives of both the parties.

ARTICLE 2.0 SCOPE OF WORK

2.1 The contractor shall perform faithfully everything required to be performed and shall provide and furnish all the labour, materials and equipment required to perform and complete, in a workman like manner, all the work covered under the contract, in strict accordance with the drawings and specifications and conditions specified in contract documents as mentioned herein above at Article 1.0.

2.2 The scope of work shall also include all such items which are not specifically mentioned in the contract documents but which are necessary for the satisfactory completion of the entire scope of works envisaged under this contract unless otherwise specifically excluded.

ARTICLE 3.0 TIME SCHEDULE

3.1 The work under this contract shall commence fromand shall be completed and ready for handing over to the Engineer-In-Charge as per agreed construction schedule / Bar Chart.

ARTICLE 4.0 WAIVER OF RIGHTS

4.1 Neither the inspection by the OWNER or the Engineer-In-Charge or any of their officials, employees of agents nor any order by the OWNER or the Engineer-In-Charge for payment of money or any payment for or acceptance of, the whole or any part of the works by the OWNER or the Engineer-In-Charge nor any extension of time nor any possession taken by the Engineer-In-Charge shall operate as waiver of any provisions of the contract, or any power herein reserved, nor shall any waiver of any breach in the contract be held to be a waiver of any other or subsequent breach.

ARTICLE 5.0 SETTLEMENT OF DISPUTES

5.1 It is specifically agreed by and between the parties that all the difference or disputes arising out of the contract or touching the subject matter of the contract shall be decided as per relevant clause of the General Conditions of Contract.

ARTICLE 6.0 NOTICE OF DEFAULT

6.1 Notice of default given by either party to the other party under the agreement shall be in writing and shall be deemed to have been duly and properly served upon the parties hereto if delivered against acknowledgement.

In witness whereof, the parties through their, duly authorized representatives have executed these presents (execution where of has been approved by the competent authorities of both the parties) on the day, month and year first above mentioned at.

For & on behalf of Contactor

For & on behalf of Corporation

.....

.....

WITNESS

- | | |
|----|----|
| 1. | 1. |
| 2. | 2. |



BANK GUARANTEE FOR EARNEST MONEY DEPOSIT

(Refer clause No. 1.31.0(c) of ITB)

(To be submitted on non-judicial stamp paper, purchased in the issuing bank, of value applicable in the state where Bank Guarantee is being executed and to be purchased in the name of the issuing Bank, which should be a Nationalized/ Scheduled Bank acceptable to the company)

To:
THDC India Ltd.
.....(India)

Dear Sir,

In accordance with your Notice Inviting Tenders for _____
under your specification no _____ dt.M/s _____ (hereinafter
called the Bidder which expression shall include their successor and assigns).

1. Whereas it is a condition in the tender documents that the tenderer has to deposit Earnest Money with respect to the tender, with THDC India Ltd. (hereinafter referred to as "Corporation") amounting to Rupees _____ or alternatively the tenderer is required to submit 'Bank Guarantee' from a Scheduled Bank/ foreign bank acceptable to the Corporation, irrevocable and operative till 30 days after the validity of the offer, for the like amount which amount is likely to be forfeited on the happening of contingencies mentioned in the tender documents.
And whereas the tenderer has offered to furnish a Bank Guarantee for the sum of Rupees _____ to the Corporation instead of deposit of earnest money.
2. Now therefore, we the _____ Bank a body corporate constituted under the banking Companies (Acquisition and Transfer of Undertaking) Act, 1969 and having a branch office at _____ (hereinafter referred to as the Bank) do hereby undertake and agree to pay unconditionally on demand in writing by the Corporation, the amount of Rs. _____ (Rupees _____ only) to the THDC India Ltd. without any demur reservation or recourse.
3. We, the aforesaid Bank, further agree, that the Corporation shall be the sole judge of and as to whether tenderer has committed any breach or breaches of any of the terms and conditions of the tender and the extent of loss damage, costs, charges and expenses caused to or suffered by or that may be caused to or suffered by the Corporation on account thereof the extent of the Earnest Money required to be deposited by the Tenderer in respect of said tender document and the decision of the corporation that the tenderer has committed such breaches and as to the amount or committed such breach or breaches and as to the amount or amounts of loss, damage, costs, charges and expenses caused to or suffered by or that may be caused to or suffered by the Corporation shall be final and binding on us.
4. We said Bank further agree that the Guarantee herein contained shall remain in full force and effect until it is released by the Corporation and change in the constitution, liquidation or dissolution of the Tenderer, shall not discharge or our liability guaranteed herein.
5. It is further declared that it shall not be necessary for the Corporation to proceed against the contractor before proceeding against the Bank and the Guarantee herein contained shall be enforceable against the Bank notwithstanding any security which the Corporation may have obtained or shall obtain from the contractor at the time when proceedings are taken against the Bank for whatever amount may be outstanding or unrealized under the Guarantee.



6. The right of the Corporation to recover the said amount of Rs. _____ (Rupees _____ only) from us in manner aforesaid will not be affected or suspended by reason of the fact that any dispute or disputes have been raised by the said M/s _____ (Tenderer) and / or that any dispute or disputes are pending before any authority / office tribunal or arbitrator (s) etc.
7. Notwithstanding any thing stated above our liability under this guarantee shall be restricted to Rs. _____ (Rupees _____ only) and our guarantee shall remain in force upto _____ and unless a demand or claim under the guarantee is made on us in writing within _____ months after the aforesaid date i.e. on or before the _____ all the Corporation's rights under the guarantee shall be forfeited and we shall be relieved and discharged from all liabilities there under.
8. The undersigned has the power to issue this guarantee under bank Memorandum and Articles of Association and the person who is hereby executing this deed has the necessary power to do so under the Power of Attorney granted to him by the bank.

Dated:

Signature _____

Place:

Name _____

Designation _____

In response of: _____

Witness:

1. Name _____
Address _____
2. Name _____
Address _____

Bank's Common Seal
Authorization No.



BANK GUARANTEE FOR PERFORMANCE SECURITY

(Refer clause No. 4.1.1 (b) of GCC)

(To be submitted on non-judicial stamp paper, purchased in the issuing bank, of value applicable in the state where Bank Guarantee is being executed and to be purchased in the name of the issuing Bank, which should be a Nationalized/Scheduled Bank acceptable to the company)

No. _____

Date: _____

To:
THDC India Ltd.
..... (India)

Dear Sir,

In consideration of your agreeing to accept the security deposit of Rs. _____ (Rupees _____ only) furnish-able to you by M/s..... hereinafter referred to as "Contractor" which expression shall unless repugnant to subject shall include its successors and assigns in terms of their Contract/ LOA No. _____ dt.....for the work of with you pursuant to your invitation to such tender and your General and Special conditions of the contract and other tender documents relating thereto subject to the conditions and alterations mutually agreed upon and set forth or referred to in your contract/LOA No..... dt.....

Expression shall include formal contract between you and the contractor in the form of guarantee from us in the manner hereinafter contained, we (Name of the Bank) having our Registered Office at..... and local Office at..... do hereby covenant and agree with you as follows:

- 1.....We undertake to indemnify you and keep you indemnified from time to time to the extent of (Rupees.....only) from and against losses and damages caused to or suffered by you due to reason of any breach or breaches on the part of contractor of any of the terms and conditions contained in the said contract and in the event the contractor shall make any default or defaults in carrying out any of the works under the said contract or otherwise in the observance and performance of any of the terms and conditions relating thereto in accordance with the true intent and meaning thereof, we shall forthwith on demand and without demur or protest, pay to you such sum or sums not exceeding in total the said sum of Rs..... (Rupees.....only) as may be claimed by you to be due from the contractor by way of such losses and / or damages, costs, charges or expenses by reason of such default or defaults on the contractor.
2. Notwithstanding anything to the contrary your decision as to whether the contractor has made any such default or defaults and the amount or amounts to which you are entitled by reasons thereof will be binding on us and we shall not be entitled to ask you to establish your claim or claims under this Guarantee but will unconditionally pay the same forthwith on your demand without any protest or demur.
3. This guarantee shall continue and hold good and shall remain in full force and effect during the period that would be taken for the performance of the said contract and till all your dues under the said contract or by virtue of any of the terms and conditions governing the said contract have been fully paid and its claims satisfied or discharged and the contractor has produced a certificate of due completion of the work under the said contract and submitted a "No Due Certificate" provided always this guarantee shall in no event remain in force after the day ofwithout prejudice to your claim or claims arisen and demanded



from or otherwise notified to us in writing before the expiry of six months from the said date which will be enforceable against us notwithstanding that the same is or are enforced after the said date.

4. Should it be necessary to extend this guarantee on account of any reason whatsoever, we undertake to extend the period of this Guarantee on your request till such time as may be required by you. Your decision in this respect shall be final and binding on us.
5. You will have the fullest liberty without affecting this guarantee from time to time to vary any of the terms and condition of the said contract or extend the time of performance of contract or to postpone for any time or from time to time any of your rights or power against the contractor and either to enforce or for bear to enforce any of the terms and conditions of the said contract and we shall not be released from our liability under this guarantee by the exercise of your liberty with reference to matter aforesaid or by the reason of any time being given to the contractor or any other forbearance, act or omission on your part or any indulgence by you to the contractor or by any variation or modification of the said contract or any other act, matter or thing whatsoever, which, under the law relating to securities, would but for the provisions hereof, have the effect of so releasing us from our liability hereunder provided always that nothing herein contained will enlarge our liability hereunder beyond the limit of Rs.....(Rupees only) as aforesaid or extend the period of the guarantee beyond the said day of writing.
6. This guarantee shall not in any way be affected by your taking or varying or giving up any securities from the contractor or any other person, firm or company on its behalf or by the winding up, dissolution, insolvency or death as the case may be of the contractor.
7. In order to give full effect to the guarantee herein contained, you shall be entitled to act as if we were your principal debtors in respect of all your claim against the contractor here by guaranteed by us as aforesaid and we hereby expressly waive all our rights or surety ship and other rights, if any, which are in any way inconsistent with any of the provisions of this guarantee.
8. Subject to the maximum limit of our liability as aforesaid this guarantee will cover all your claim or claims against the contractor from time to time arising out of or in relation to the said contract and in respect of which your claim in writing is lodged on us before expiry of six months from the date of expiry of this guarantee.
9. Any notice by way of demand or otherwise hereunder may be sent by special courier, telex or registered post to our local address as aforesaid and if sent by post, it shall be deemed to have been given when the same has been posted.
10. This guarantee and the power, and provision herein contained are in addition to and not by way of a limitation or substitution for any other guarantee or guarantees here to force given to you by us (whether jointly with others or alone) and now existing un-cancelled and that this guarantee is not intended to and shall not revoke or limit such guarantee or guarantees.
11. This guarantee shall not be affected by any change in the constitution of the contractor or us nor shall it be affected by any change in your constitution or by any amalgamation or absorption thereof or therewith but will ensure for the benefit of and the available to and enforceable by the absorbing or amalgamated company or concern.
12. This guarantee is irrevocable during the period of its currency and shall not be revoked without your previous consent in writing.
13. We further agree and undertake to pay you the amount demanded by you in writing irrespective of any dispute or controversy between you and the contractor or any suit or proceeding pending before any arbitrator, tribunal or court relating thereto.



14. It shall not be necessary for you to proceed against the contractor before proceeding against the bank for any legal action and the guarantee herein contained shall be enforceable against the bank, notwithstanding any security which you may have obtained or obtain from the contractor shall at the time when proceedings are taken against the bank hereunder be outstanding or unrealized.

15. Notwithstanding anything contained herein above liability under this guarantee is restricted to Rs.....(Rupees..... only) and this guarantee shall remain in force until and unless a written claim is lodged on us for payment under this guarantee withinmonths from the date of expiry of this guarantee i.e. on or beforeall your rights under this guarantee shall be forfeited and we shall be deemed to have been released and discharged from all liabilities there under, irrespective of whether or not the original guarantee is returned to us.

16. We have power to issue this guarantee in your favour under the memorandum and Articles of Association of the Bank and the undersigned has full power to execute this guarantee under the Power of Attorney granted to him by the Bank.

For & on behalf of

(Banker's Name)

Branch Manager

Banker's Seal

Authorization No

Address: _____

Witness:

- 1. Name _____
Address
- 2. Name ____
Address



PROFORMA FOR INDEMNITY BOND FOR FREE ISSUE ITEM

(To be submitted on Non-Judicial stamp paper of value applicable in the State where bond is being executed.

This should be signed by the person who has got power of Attorney to execute such bond)

Ref. No.

Dated.....

This indemnity Bond is executed by M/s proprietary firm/Partnership firm/Pvt. Ltd./ a company incorporated under the companies Act, 1956 having its registered office atin the state of hereinafter referred to as “Contractor” (Which expression shall unless repugnant to the context or the meaning thereof, be deemed to include its successors and assigns) in FAVOUR OF THDC INDIA LIMITED, a company incorporated under companies Act, 1956 and having its registered office at Bhagirathi Puram, Tehri, Garhwal, hereinafter called as THDCIL (Which expression shall, unless repugnant to the context or the meaning thereof, be deemed to include its successors and assigns.).

Whereas THDCIL and the Contractor have entered into a Contract no. Dated wherein the contractor has to execute the works as stipulated in the contract.

And whereas the aforesaid contract interalia provides for taking the delivery of some materials equipment/ components as listed in Annexure-1 along at Rs. attached herewith required for completion of the works. The Contractor shall indemnify THDCIL to the extent of the value of the material equipment and components received by the Contractor by executing indemnity bond in favour of THDCIL against loss or damage to them.

1. Now therefore, the condition of this bond is such that on utilization of materials/ installation of the components and equipment as per the contract, the Contractor’s liability under this indemnity shall stand discharged and this Bond shall become void.
2. The Contractor hereby agree convenient and undertake with THDCIL that:
 - (a) We shall hold these material/ equipment/ components in our safe custody after receipt of material equipment and components in our possession and during transit.
 - (b) The said materials/ equipment and components will be held in trust by us for THDCIL and we shall not create any charge, trust, Hypothecation, rights of possession, pledge, lien, claim or encumbrance whatsoever thereon or any part thereof save and except the trust created in favour of THDCIL by us as stated above.
 - (c) The said materials/ equipment and components kept in trust shall be without prejudice to the provisions of the contract as to inspection or rejection by THDCIL.
 - (d) We undertake and declare that the materials/ equipment and components will be used for the only purpose and use as stipulated in the said contract and that they shall not be used otherwise without the written permission of the authorized officer of THDCIL specified in this behalf.
 - (e) We shall be entirely responsible and liable for the safe custody and protection of the said materials/ equipment and components against all insurable risk and we further agree and undertake that we shall indemnify THDCIL against any loss, damage or deterioration whatsoever of the said materials/equipment



and components and the same shall at all times be open to inspection of any officer authorized by THDCIL. We shall take all precautions and care for safe and proper custody of the said materials/equipment and components. And use the same solely in execution of the order in accordance with the terms and conditions thereof and shall not in any way deal with the said materials/equipment and components contrary to the interest of THDCIL. We shall also furnish statements, bills, status and utilization report and other records etc. as may be required by THDCIL from time to time about the said materials/equipment and components.

- (f) Should any loss or damage occur to any of the said materials/equipment and components or any refund becomes due, THDCIL shall be entitled to recover from us compensation for such loss or damages, the amount to be refunded without prejudice to any other remedies available to THDCIL by deduction from any sum due or any such sum which at any time hereinafter may become due to us under said contract or from any sum paid by us by way of Security Deposit etc.
- (g) We undertake to duly insure and keep insured at our cost the materials/equipment and components which are the subject matter of this bond for the full value thereof with insurance company as may be or is specified by THDCIL, against risk of loss, fire, theft, deterioration or damages for any reason whatsoever and to deliver to the photo copy of the policy of insurance to THDCIL and shall pay all the premium and other sums of money necessary for keeping the policy of insurance in force and to handover the receipt for such payment whenever called upon by THDCIL. We further undertake to keep such policy/policies in force till the time materials/equipment and components are utilized for the works as per aforesaid contract.
- (h) We confirm that once the materials are received by us they shall be deemed as accepted by us unless otherwise pointed out by us in writing a week after taking delivery. However, if any package/packages is/are found damaged or broken at the time of taking delivery, the same will be pointed out by us in writing on transporter's delivery challan in presence of transporter's representative and one copy of such delivery challan will be sent to THDC immediately thereafter by registered post.
- (i) In the event of failure to fulfill all our obligation under the said contract THDCIL will be entitled to take possession of the said materials/equipment and components remaining in our custody without prejudice to any claim and remedies under the said contract and under law.
- (j) In the event of any of dispute of difference arising under the terms of this Bond or in connection thereof, the courts at shall have the jurisdiction to the exclusion of all other courts.

Date :

Place :

For and on behalf of Contractor

Witness : _____

1- _____

2- _____

Encl. 1) Annexure



RTGS/ NEFT Payment Details
(Refer clause no 1.13.0 of Section-II –ITB)

SI No.	Details	To be filled up by Bidder
1.	Tender No.	
2.	Name of bidder	
3.	Account No.	
4.	Bank Name	
5.	Branch Address of Bank	
6.	PAN No.	

A. Payment of cost of bid document

SI No.	Details	To be filled up by Bidder
1.	Transaction No.	
2.	Transaction Date	
3.	Copy of receipt	Enclosed
4.	Amount in Rs.	

B. Payment of EMD

SI No.	Details	To be filled up by Bidder
1.	Transaction No.	
2.	Transaction Date	
3.	Copy of receipt	Enclosed
4.	Amount in Rs.	

Signature of the authorized representative

Name _____

Designation _____

Name of the Bidder _____

Stamp of the Bidder _____



Details Regarding Ex-Employees of THDC India Limited
(On the letter head of the Bidder)

We furnish the details of ex-employees of THDC India Limited retired / resigned at the level of General Manager and above from THDC India Limited and subsequently have been employed by us:

Name of Person and designation in THDC India Limited	Date of Retirement/ resignation from THDC India Limited	Date of joining and designation in bidder's organization

Signature of the authorized representative

Name _____

Designation _____

Name of the Bidder _____

Stamp of the Bidder _____



No Claim Certificate

(Refer clause no. 5.1.0 (a) of GGC)

Name of the Contractor:

Contract No:

Name of the work:

Certified that I / we have no claim pending against work executed by me/ us against Contract Agreement no
.....

Or

Certified that I/we have no claim pending against work executed by me/ us against Contract Agreement no
..... except the following, which have already been submitted and pending.

SI No	Particulars of Claim	Claim Amount	Claim pending with

This certificate is issued without any duress for the purpose of processing Final Bill of the work executed against the captioned agreement/ release of Performance Security.

Date:

Name and Signature

(Contractor/ Authorized Officer)



PROFORMA FOR MATERIAL ACCOUNTING

(Refer clause no. 15.02.08 (c) of GCC)

Name of MaterialReconciliation on

1. Name of the Contractor:
2. Name of the Project:
3. Name of the Work:
4. Contract No. :
5. Location of the Contractor's stock/godown :
6. Total estimated requirement in the contract:
7. Value of the material security Bank Guarantee furnished:
8. Value of the security towards other materials:
9. Value of security under this performance:

Note:

- (i) Fill separate proforma for
 - a. Cement
 - b. Tor-Steel Reinforcement
(Section wise/Diameter wise)
 - c. Structural Steel
(Section wise)
- (ii) Same proforma to be used till it is filled by succeeding reconciliation. Fresh proforma for each reconciliation is prohibited.

(Signature of the authorized representative)



CONDITION FOR BIDDER

The copies of requisite document/certificates shall be self attested by the bidder while submitting the bid. However, the original documents/certificates shall be produced by the bidder for verification, if required by the Owner at any time. Further, the bidder shall be required to furnish a declaration as under alongwith his bid.

“I/We hereby solemnly declare that the document/certificates/information submitted with the bid are genuine and true to the best of my knowledge. If the document/certificates/information submitted with the bid are found fake/false at any point of time, the responsibility for the same and consequences thereof shall solely rest with the bidder only and in that event the owner shall be entitled to take action as may be deemed fit to debar the bidder/contractor, cancel the contract including forfeiture of EMD/Performance Security Deposit etc.”

(Signature of the Bidder)



PROCEDURE FOR DRAW (SCC Clause)

Name of work: - Construction of Rock fall protection barrier for B-Block colony at VPHEP.

NIT No. :- THDCIL/VPHEP/PKOTI/22-23/04 , Dtd.

Date and Time of Draw: -

Venue: -

टाई बिडरों में से एक सफल बिडर (**Successful bidder**) के चयन के लिए ड्रा की प्रक्रिया का विवरण:-

1. ऑफलाइन मोड में ड्रा की प्रक्रिया टाई बिडर के प्रतिनिधियों की उपस्थिति में, जो प्रक्रिया में भाग लेने के इच्छुक हों एवं टीएचडीसी प्रतिनिधि/निविदा समिति के सम्मुख किया जायेगा, जिसकी पूर्ण विडियोग्राफी की जायेगी।
2. प्रत्येक टाई बिडर का नाम एक समान कागज की पर्ची पर इस प्रकार लिखा जायेगा कि बिडर का नाम अन्दर की तरफ हो और दिखाई न दे। पर्ची को एक समान तरीके से फोल्ड कर बिडरों के प्रतिनिधियों को दिखाकर स्टेपल किया जायेगा एवं स्टेपल की गयी पर्चीयों पर “**Properly sealed**” लिख कर बिडरों के हस्ताक्षर करवाकर उनको पुनः एक बार फोल्ड करके स्टेपल कर दिया जायेगा जिससे की फोल्डेड पर्ची के दोनों बाहरी सतह पर कोई लिखावट न दिखे। तत्पश्चात् बन्द स्टेपल पर्चीयों को एक-एक कर के बिडरों की उपस्थिति में खाली पारदर्शी ड्रा बाक्स में डाला जायेगा।
3. बन्द स्टेपल पर्चीयों को खाली ड्रा बाक्स में डालने से पूर्व बिडरों को खाली बाक्स का निरीक्षण कराया जायेगा।
4. पर्चीयों को ड्रा बाक्स में डालने के पश्चात्, ड्रा बाक्स को उचित प्रकार से हिलाया जायेगा ताकि पर्चीयां आपस में पूर्ण रूप से मिक्स हों जायें।
5. एक ऐसे स्वतंत्र/निस्पक्ष व्यक्ति जिनके नाम पर बिडरों की सहमति हो, के द्वारा ड्रा बाक्स के अन्दर हाथ डालकर कोई एक पर्ची बाहर निकाली जायेगी एवं उस स्टेपल पर्ची के उपर सफल बिडर (**Successful bidder**) लिखने के उपरान्त बिडरों के हस्ताक्षर करवाकर तत्पश्चात् सभी प्रत्यक्ष दर्शीयों /बिडरों के सम्मुख पर्ची को खोलकर पर्ची में लिखा गया बिडर का नाम घोषित किया जायेगा।
6. चुनी हुई पर्ची पर अंकित बिडर के नाम को पूरे कार्य के आंवटन हेतु सफल बिडर घोषित किया जायेगा।
7. ड्रा के परिणाम को एक कागज पर लिखित में घोषित कर बिडरों के प्रतिनिधियों एवं टीएचडीसी प्रतिनिधियों/निविदा समिति सदस्यों द्वारा हस्ताक्षर किया जायेगा।
8. उपरोक्त पूर्ण प्रक्रिया जो स्वतः व्याख्यात्मक है, हम समस्त बिडर/प्रतिनिधि उक्त प्रक्रिया से पूर्ण रूप से सन्तुष्ट हैं, उपरोक्त प्रक्रिया से घोषित परिणाम अन्तिम होगा एवं हमको हर प्रकार से मान्य होगा।

श्री/श्रीमती.....को ड्रा बाक्स से पर्ची निकालने हेतु बिडरों के प्रतिनिधियों की सहमति से अधिकृत किया गया है।

S.N.	Name of Bidder	Name of authorized representative of the bidder attending the draw, with Identity No.	Signature & Date of authorized representative of the bidder.
01			



SECTION – VIII

TECHNICAL SPECIFICATION & DRAWINGS

**Technical Specification**

Item of works as referred in BOQ for "Construction of rock fall protection barrier at B-Block" colony at VPHEP shall confirm with CPWD Specifications and Non sechedule item specifications. The items which are not covered under CPWD specifications and Indian Standard Code provisions, Instructions of E-IC shall be final and binding of the contractor.

DETAILS TECHNICAL SPECIFICATION OF BOQ ITEMS:

S.No	BOQ Items No.	Specified referred items of DSR-2018/NSI/DAR2019
1	BOQ item no . 1	DSR-2018 (2.7.1)
2	BOQ item no . 2	DSR-2018 (5.9.1)
3	BOQ item no . 3	DSR-2018 (5.33.1)
4	BOQ item no . 4	DSR-2018 (10.2)
5(a)	BOQ item no . 5(a)	NSI
5(b)	BOQ item no . 5(b)	NSI
5(c)	BOQ item no . 5(c)	NSI
6	BOQ item no . 6	NSI
7	BOQ item no . 7	NSI (IS-2758-1963)
8	BOQ item no . 8	NSI (IS-2315-1978)
9	BOQ item no . 9	NSI
10	BOQ item no . 10	DSR-2018 (10.19)
11	BOQ item no . 11	NSI (IS-1266:2002)
12	BOQ item no . 12	DAR-2019 (16.70.1)

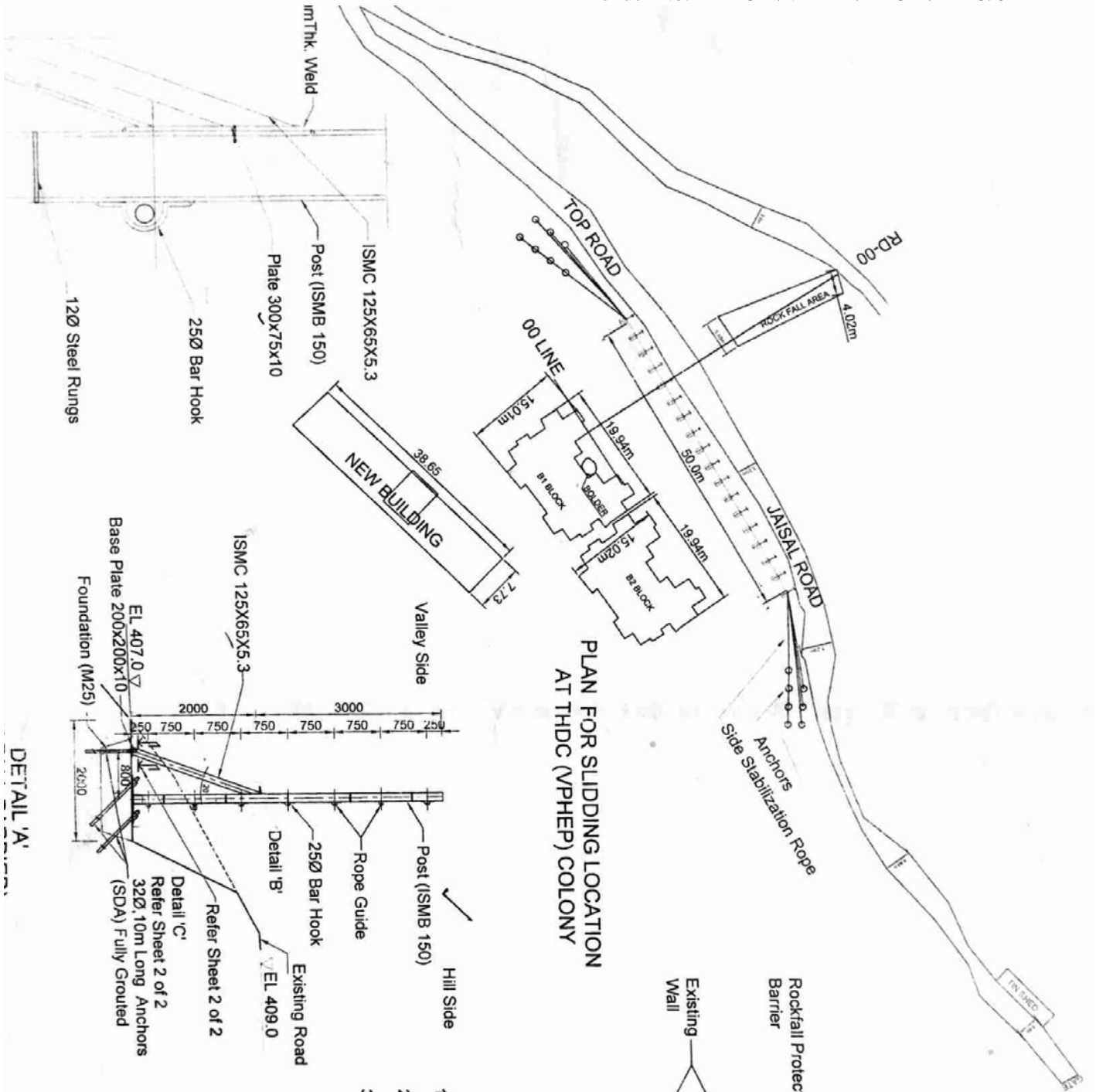

PLAN FOR SLIDING LOCATION
AT THDC (VPHEP) COLONY

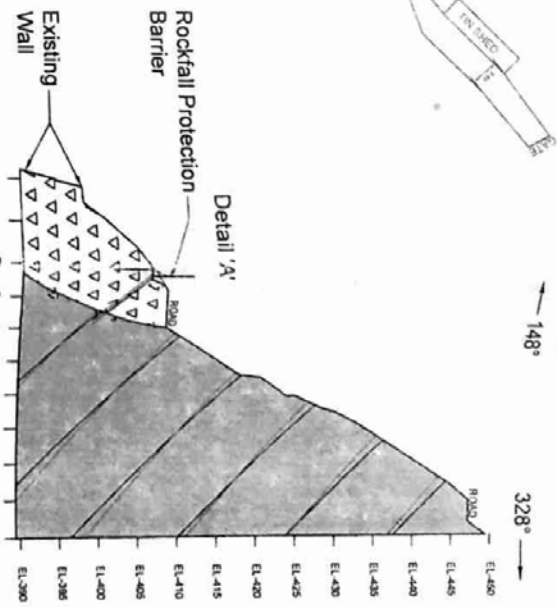

TYPICAL SECTION
(SECTION AT RD-00)

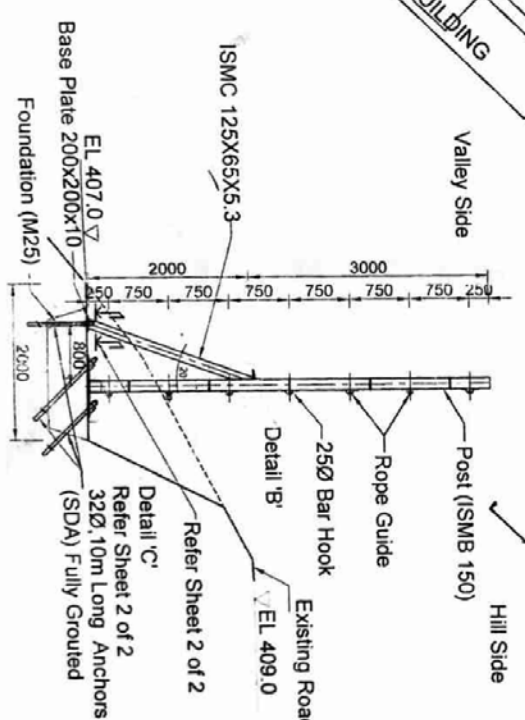

DETAIL 'A'

- NOTES:-**
1. All dimensions are in millimetres and elevations are in metres; unless specified otherwise.
 2. No dimension shall be scaled, only written dimensions are to be taken as correct.
 3. Galvanized chain link fabric shall conform to the requirements of IS: 2721-(latest) / double twisted hexagon wire mesh conforming to ASTM A975 for galvanized steel chain link fence fabric. The fabric shall have double twist & have a mesh size of 50mm x 50 mm with min. wire diameter of 3 mm.

<p>वीश्वनीसी इंडिया लिमिटेड THDC INDIA LIMITED</p>	
<p>VISHNUGAD PIPALKOTI H.E. PROJEC TYPICAL ROCKFALL PROTECTION ARRANGEMENT FOR B - BLOCK AT VPHEP (Sheet 1 of 2)</p>	
Mgr.	DGM
AGM	GM

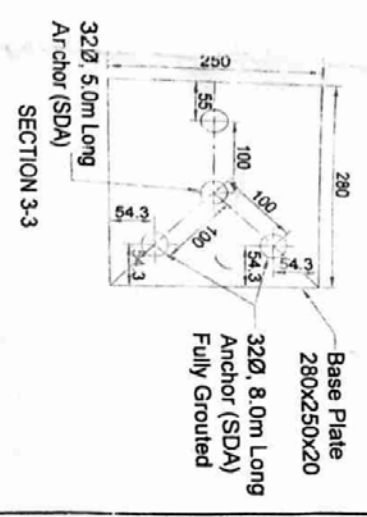
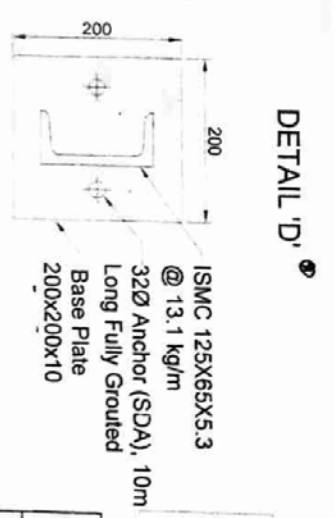
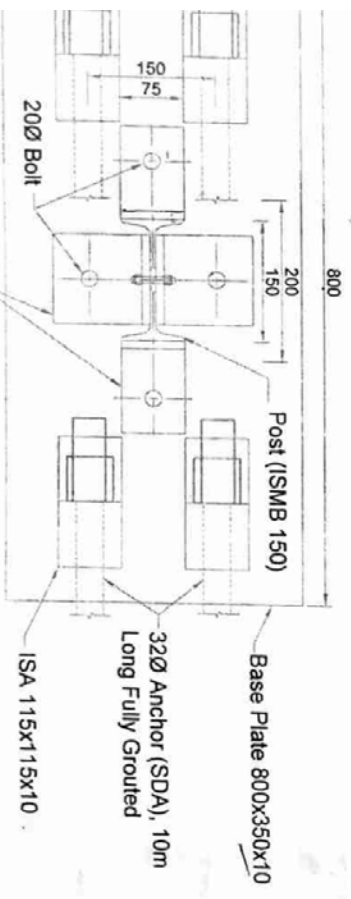
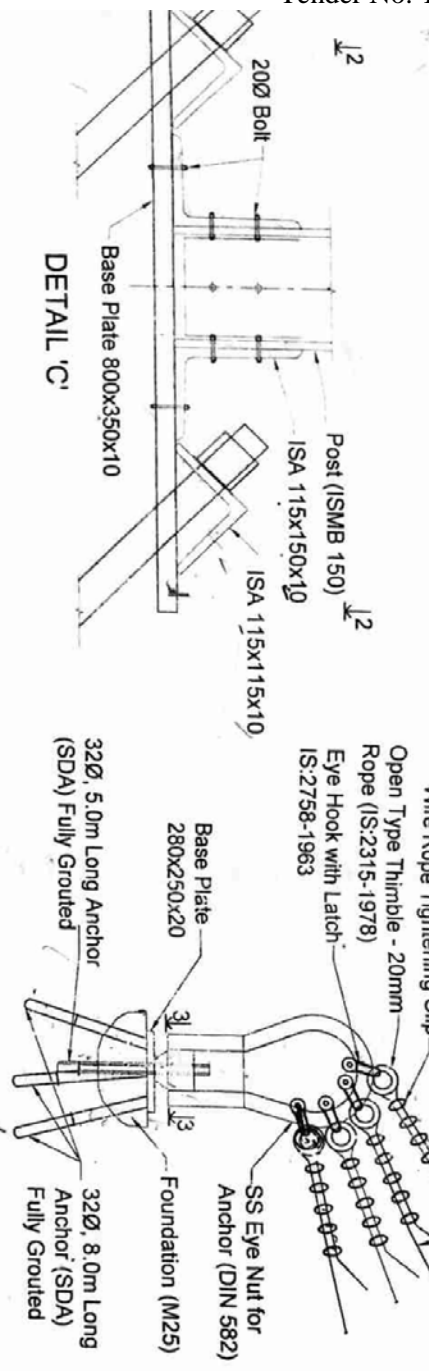
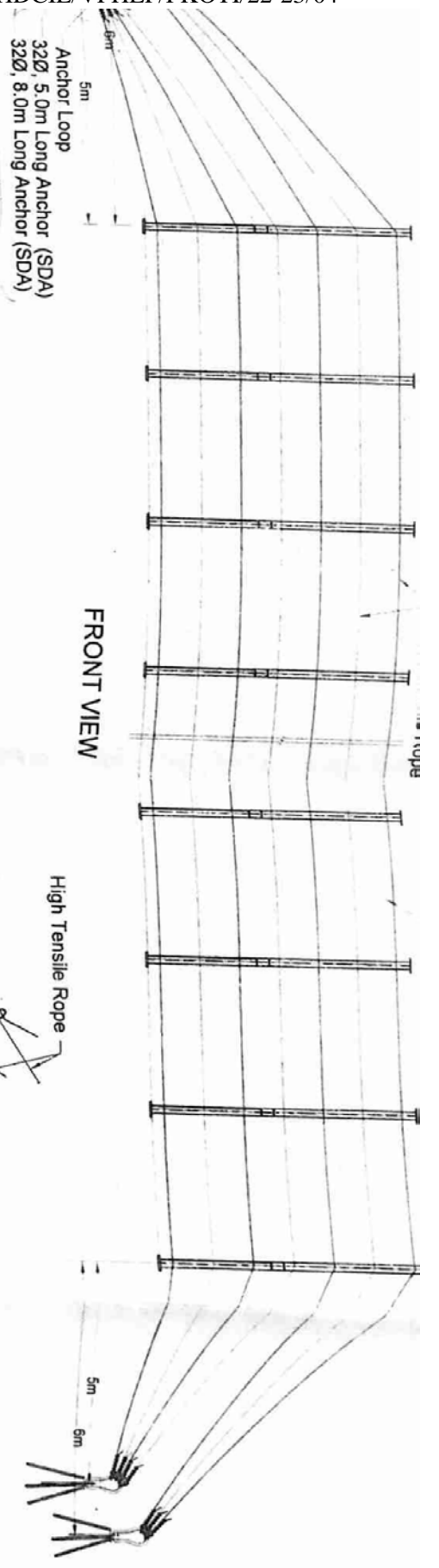

High Tensile Rope	1960 MPa (IS1266:2002)
Rope Grade	20
Rope Diameter mm	Zn or ZnAl (Class A or B)
Corrosion Protection	

टीएचडीसी इंडिया लिमिटेड
THDC INDIA LIMITED
VISHNUGAD PIPALKOTI H.E. PROJECT

TYPICAL ROCKFALL PROTECTION ARRANGEMENT
FOR B - BLOCK AT VPHEP (Sheet 2 of 2)

12/8
 1/20



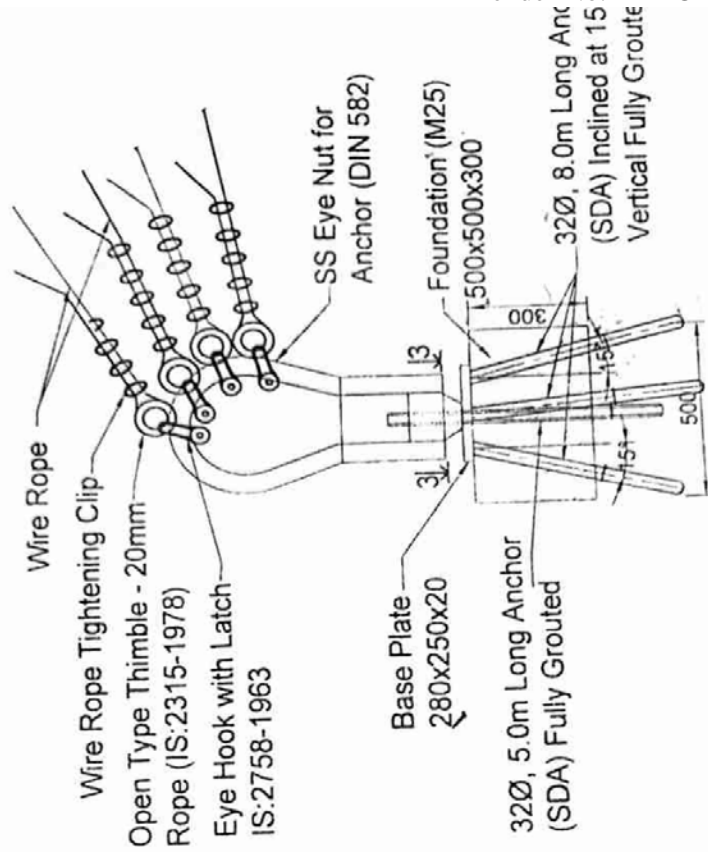
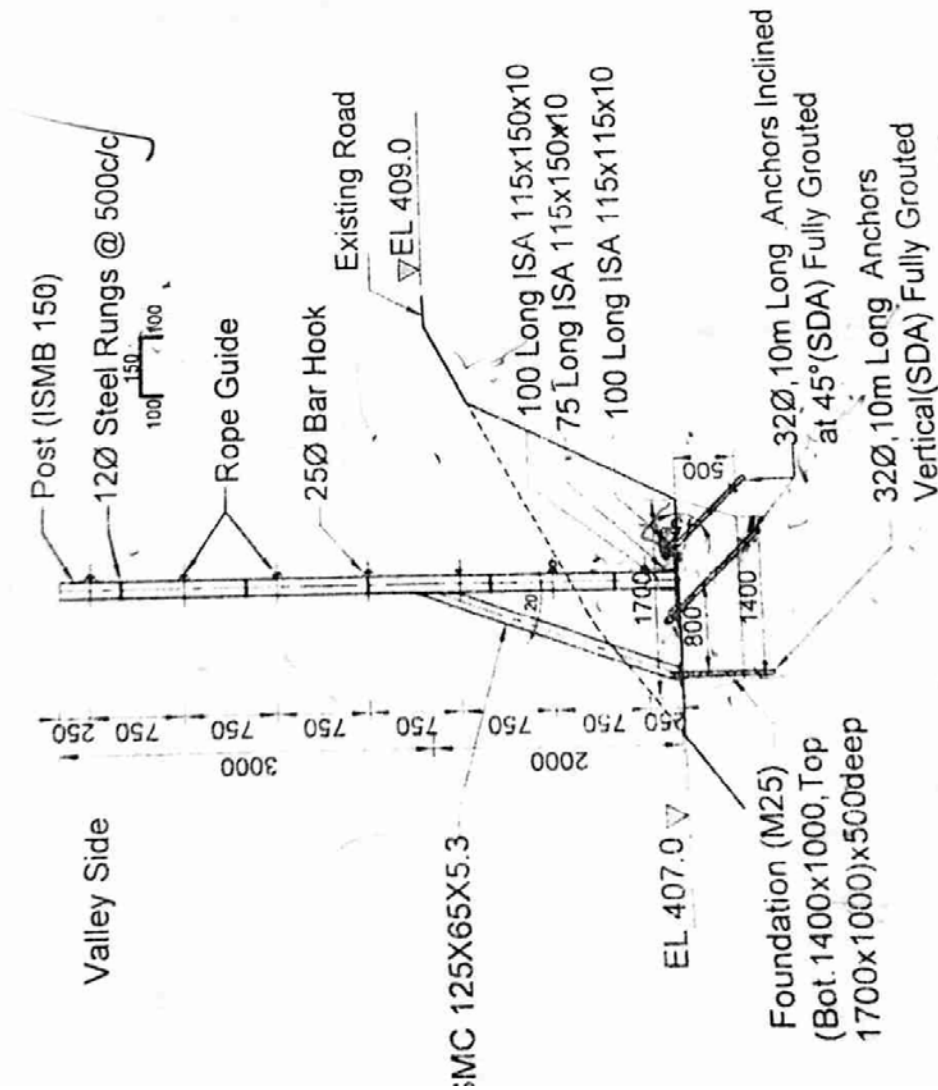

ROCK FALL BARRIER